

Installation of side-opening LD-2S hall door system



Pack

● **Hall Door Sill Installation**

The sill should be 2-5mm higher than the decoration ground. Before installing the sill, you must coordinate with the civil works contractor to confirm the height of the sill installation. The civil work contractor is required to provide the baseline of the floor for accurate construction.

1. According to the center of the sill and the net opening width, draw the net opening centerline and the net opening width on the sill with a needle (as shown below):

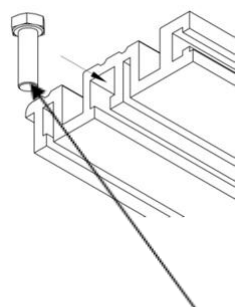
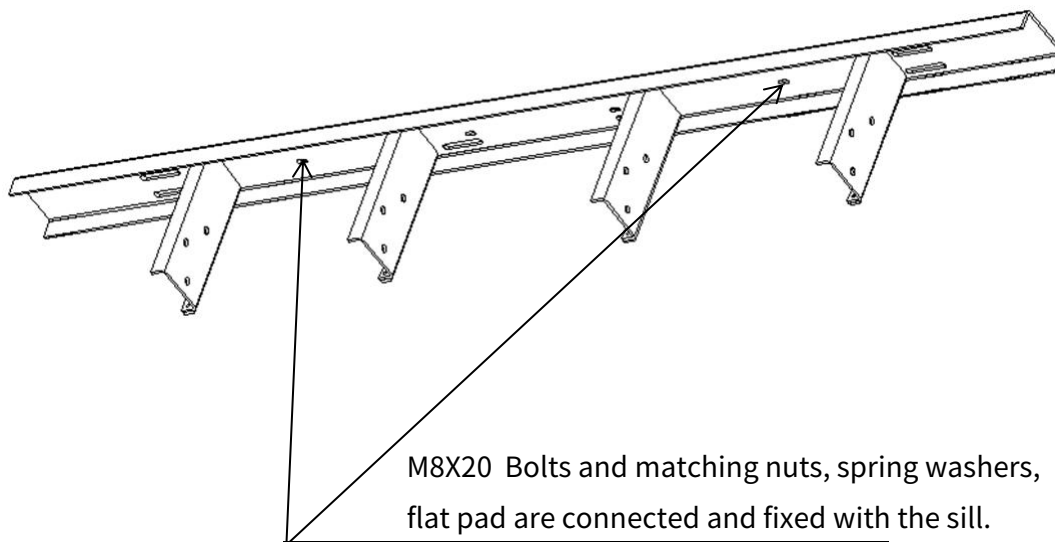
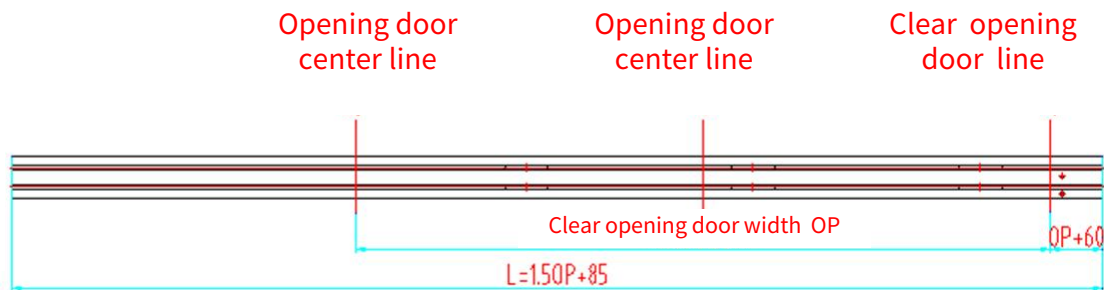

M8X30 bolt
Aluminum sill

Installation of side-opening LD-2S hall door system



Pack

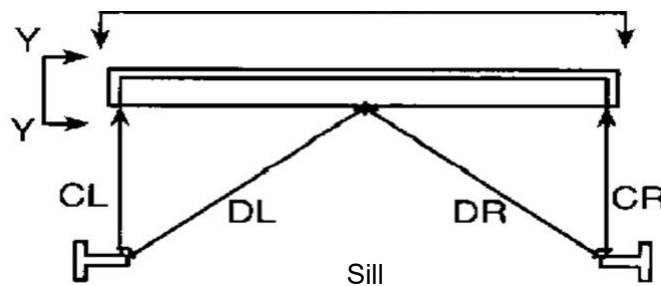
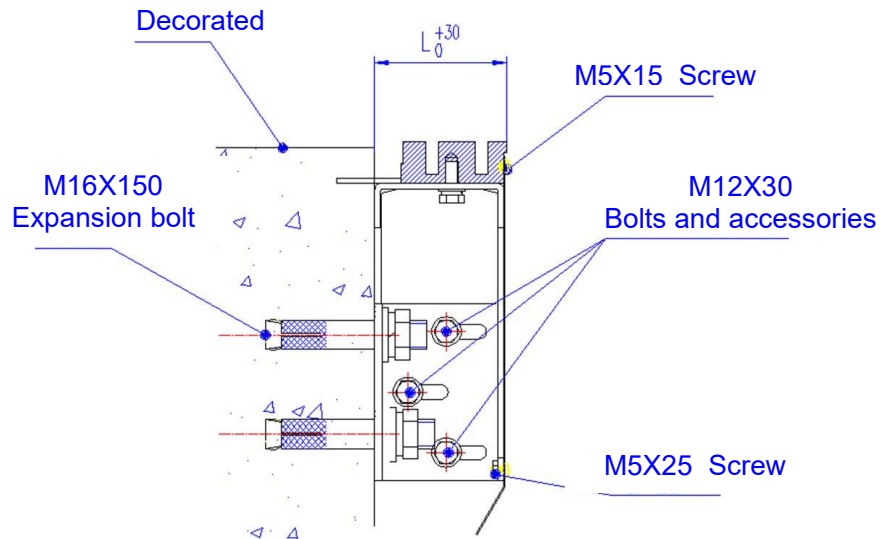

Note: The error between the center line of the sill and the equilateral DL and DR of the guide rail cannot exceed $\pm 0.5\text{mm}$.

2. When the installation is confirmed to be correct, lock all the screws, and spot weld the contact surface of the bolt flat pad and the angle iron. Paint the welded areas for touch-ups.

3. the building has cement corbels, the installation steps are as follows

- (1) Connect the small sill bracket to the sill with M6 countersunk bolts.
- (2) Pave cement concrete and put the sill upper the cement concrete .
- (3) Then adjust the height of the sill and the clearance and levelness of the car sill, (the height needs to be 2~5 mm higher than the finished surface of the floor, the gap with the car sill is 30~33 mm, and the sill levelness is 1/1000).
- (4) Cement corbel sill installation completed.

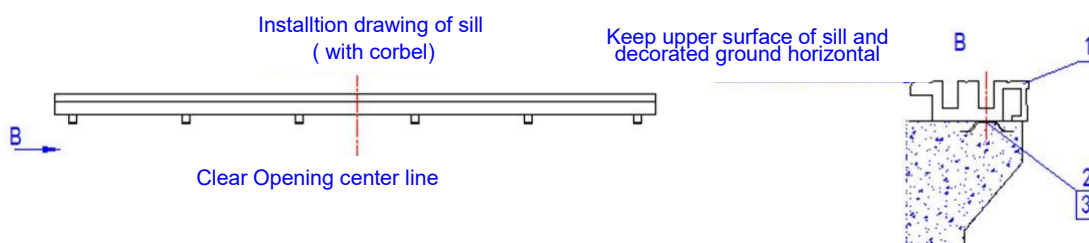

Installation Manual

Installation of side-opening LD-2S hall door system



Pack

● Hall Door Sill Installation

1. According to the center of the sill and the clear opening width, draw the net opening centerline and the clear opening width on the sill with a needle (as shown below):

(1) Divide the top frame of the door jamb and extend it to both sides with the center line as the benchmark, and mark the position when the door is fully opened with a marker (that is the clear opening width line).

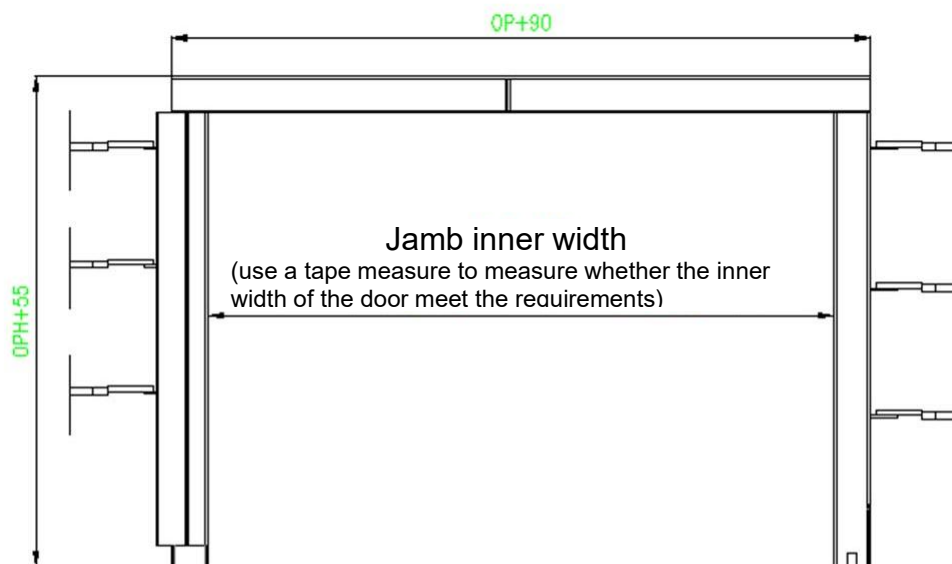
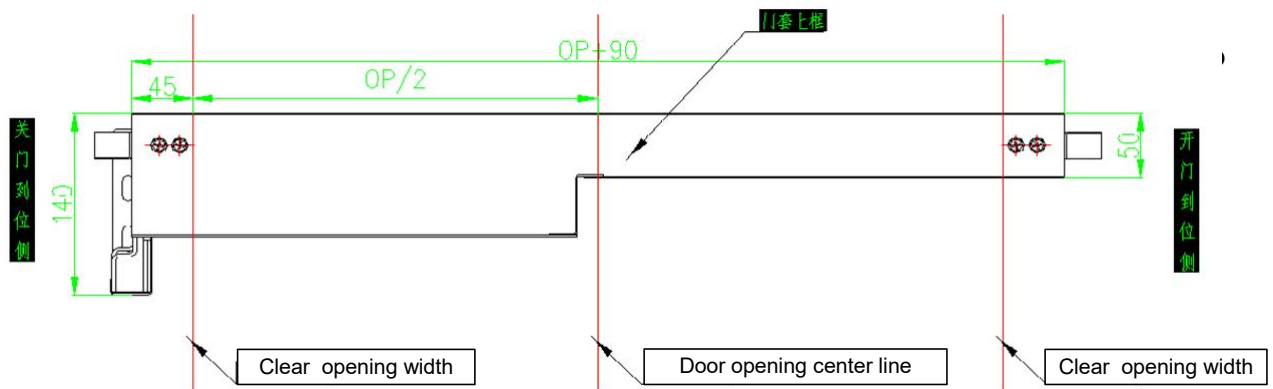

M6X16 Bolts and accessories

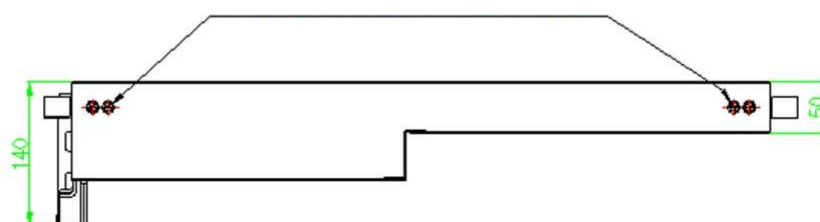

Installation of side-opening LD-2S hall door system



Pack

2. After combining the outer jamb, connect the lower fixing foot of the jamb with the installation hole of the sill installation jamb using bolts.

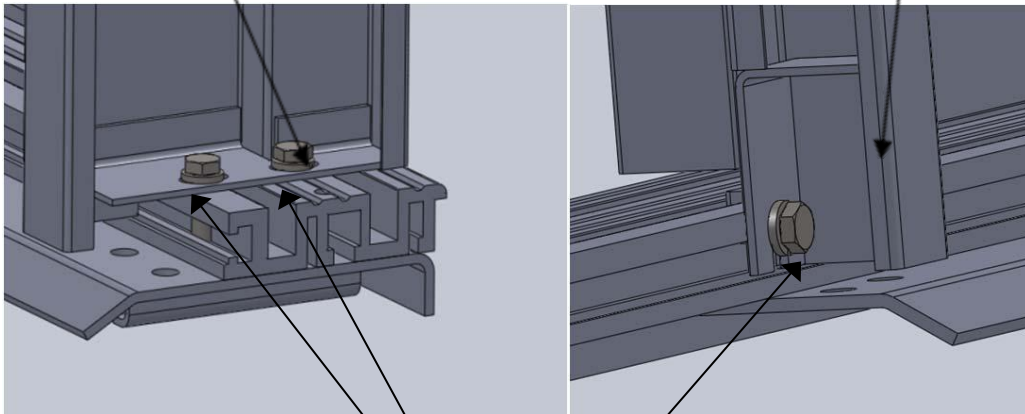
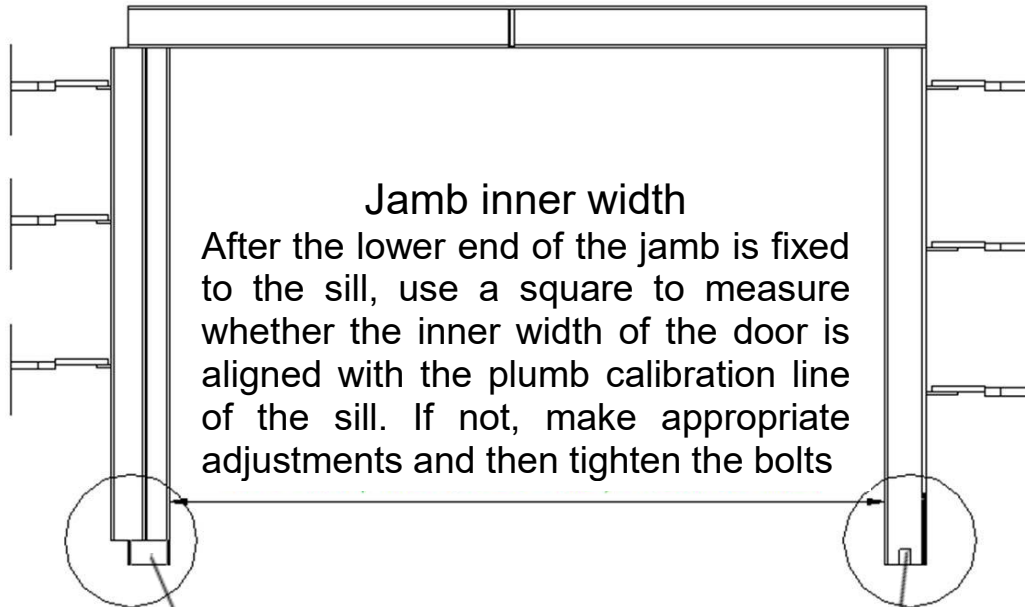

M8X20 Bolts

Fix the jamb column on the door closing side to the sill.
Fix the jamb column on the door opening side to the sill.

Installation Manual

Installation of side-opening LD-2S hall door system



Pack

3. Connection and fixation between jamb and shaft wall

(1) Determine the fixed connection point position between the shaft and Jamb

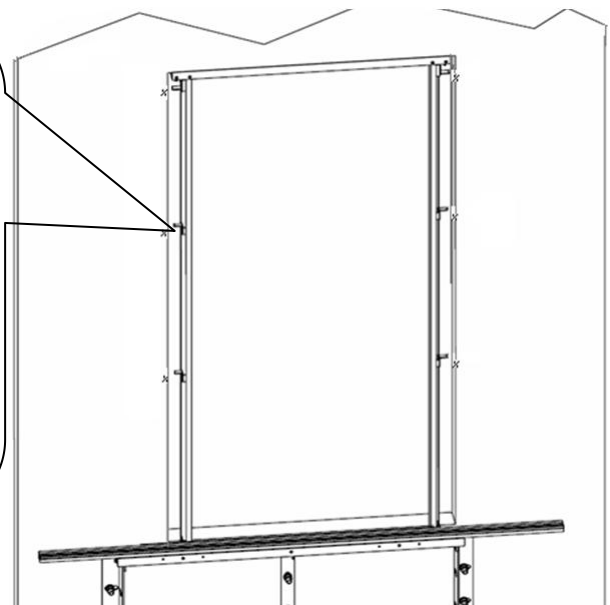
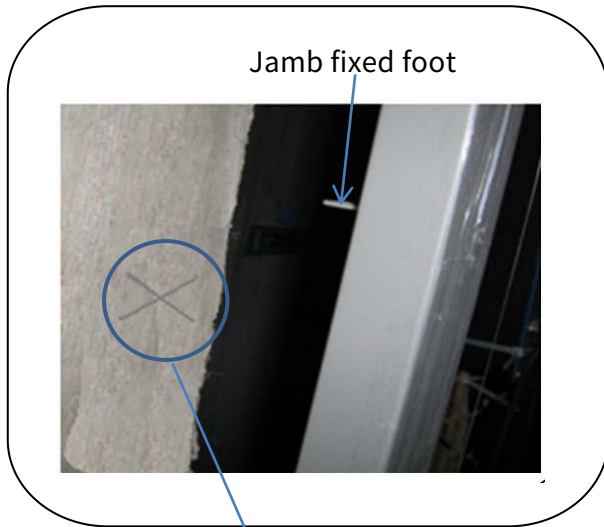

Mark with a marker pen on the door opening wall at the horizontal distance from the fixed foot of the jamb column.

(2) Use an impact drill to drill holes at the mark on the shaft wall, fix the expansion bolt on the shaft wall, and tighten the nut of the expansion bolt.

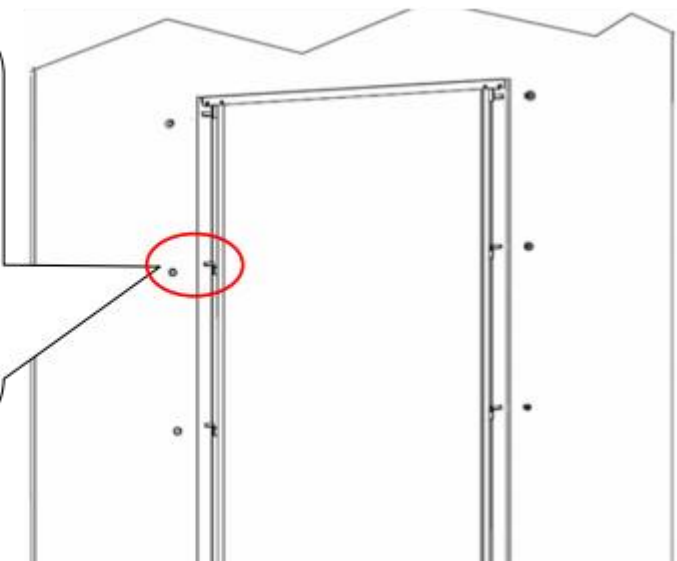
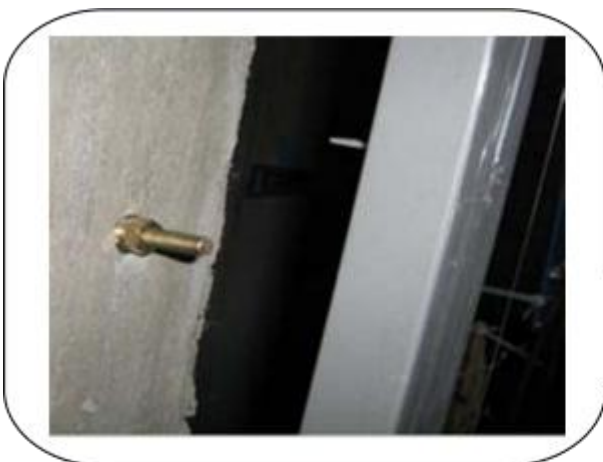

Installation of side-opening LD-2S hall door system



Pack

(3) After determining the left, right, front and rear positions of the jamb, fix the jamb to prevent it from moving.

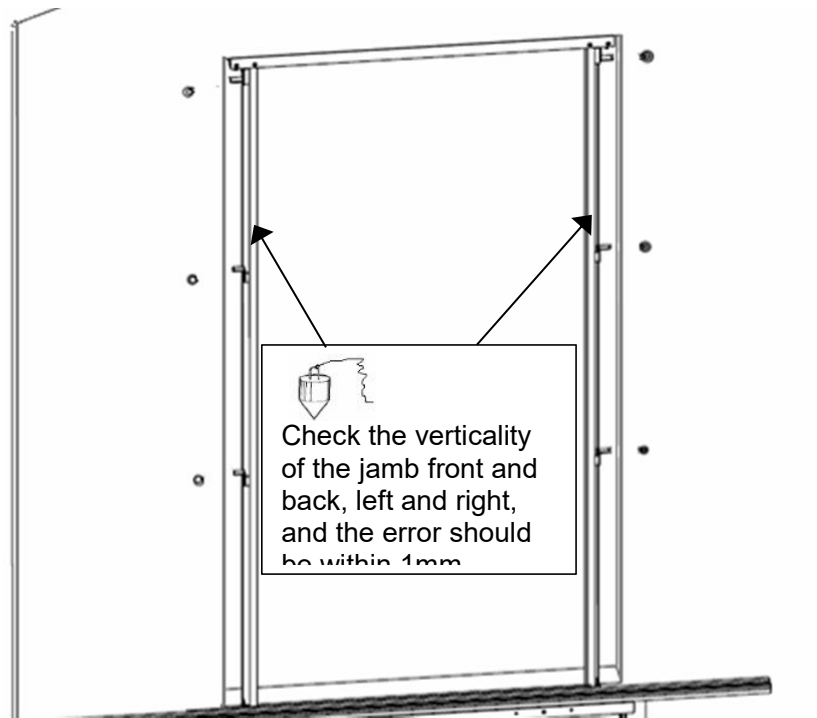

(4) Use $\Phi 8\text{mm} \times A 150\text{mm}$ round steel is used to fix the top two fixed feet of the Jamb column by welding them with expansion bolts (as shown in the following figure).

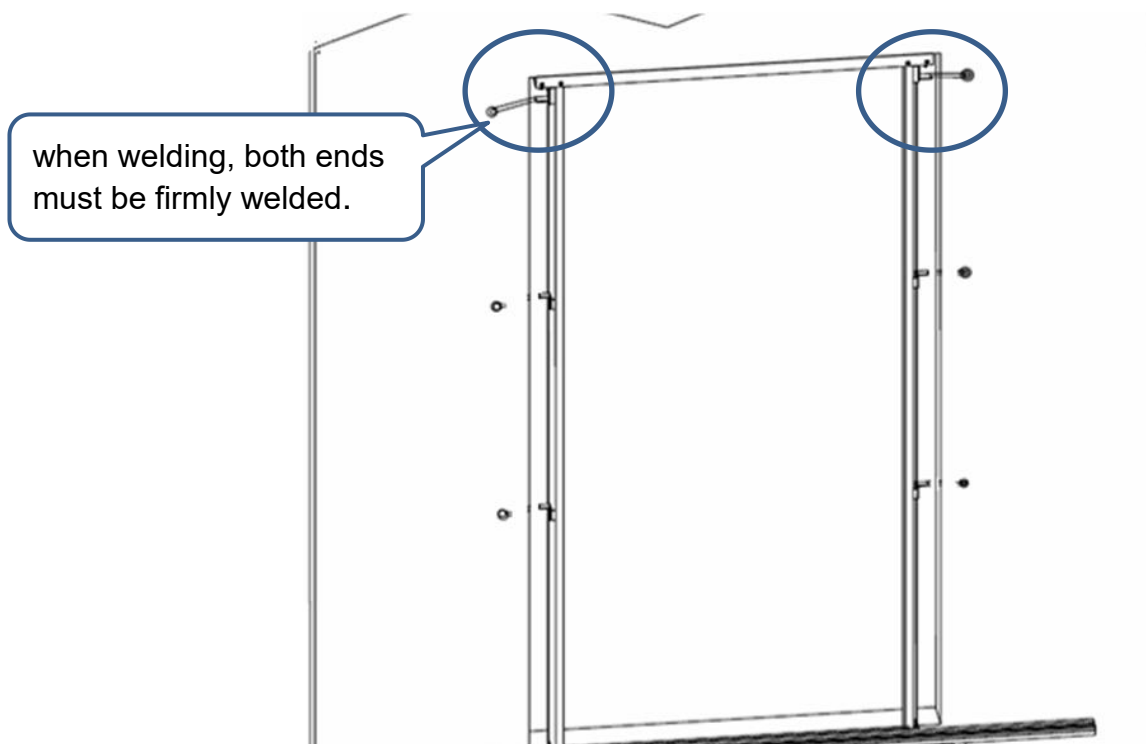

Installation of side-opening LD-2S hall door system



Pack

If the verticality and torsion meet the requirements, weld the fixed feet of the jamb column one by one with the expansion bolts (as shown in the following figure):

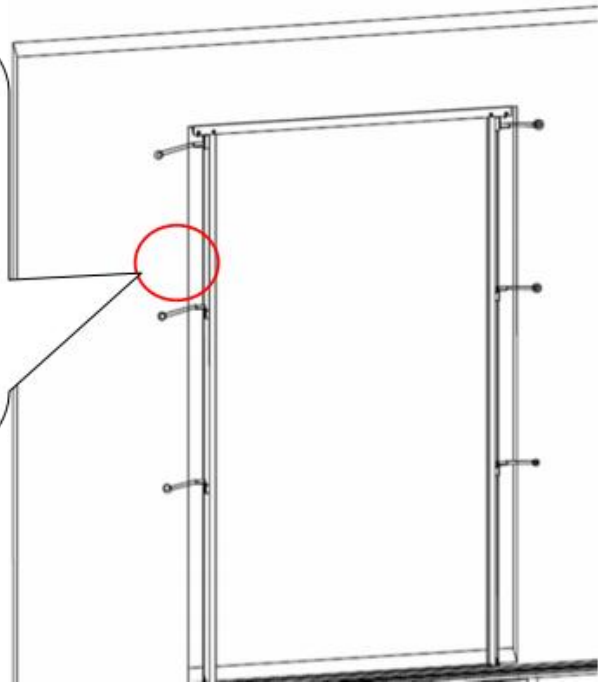

When welding, it is required to fully weld both sides of the round steel and the fixed contact surface, while removing welding slag to check whether the welding meets the requirements.

Installation of side-opening LD-2S hall door system



Pack

● Hall Door Header Installation

1. First, place the hall door header on the header bracket of the door cover (connected with bolts), keep the center point of the header aligned with the center point of the hall door sill, and place it according to the fixing frame of the hall door header (2 pieces in total) The position of the bolt fixing hole is marked on the shaft wall with a marker pen to mark the position of the fixing bolt.

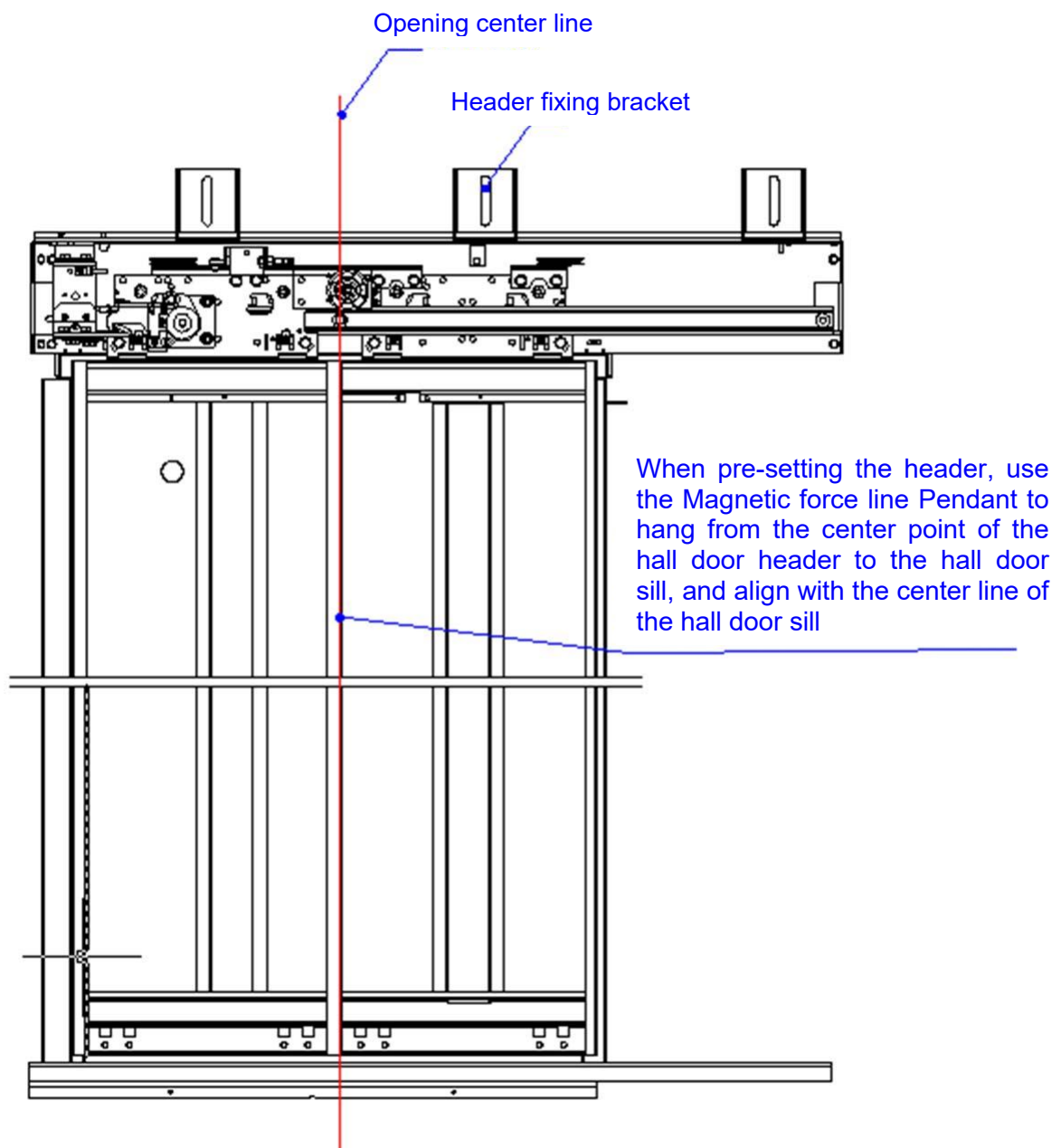

Installation of side-opening LD-2S hall door system



Pack

2. Drill holes at the marked positions with a rotary hammer and fix the expansion bolts.

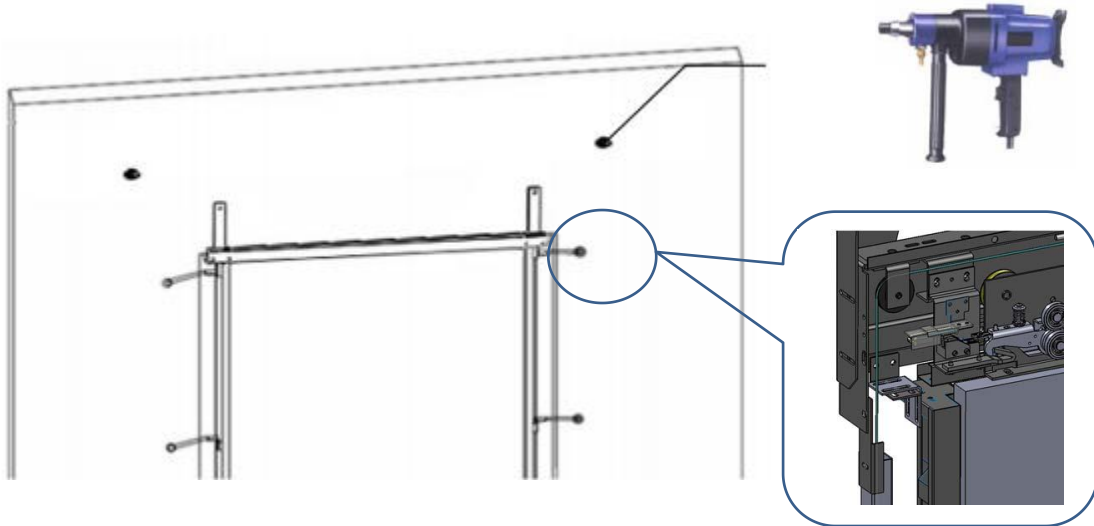

3. Connect the hall door header bracket, pass the expansion bolts on the shaft wall through the fixing holes of the hall door header bracket, and pre tighten the screws. Then make the following adjustments.

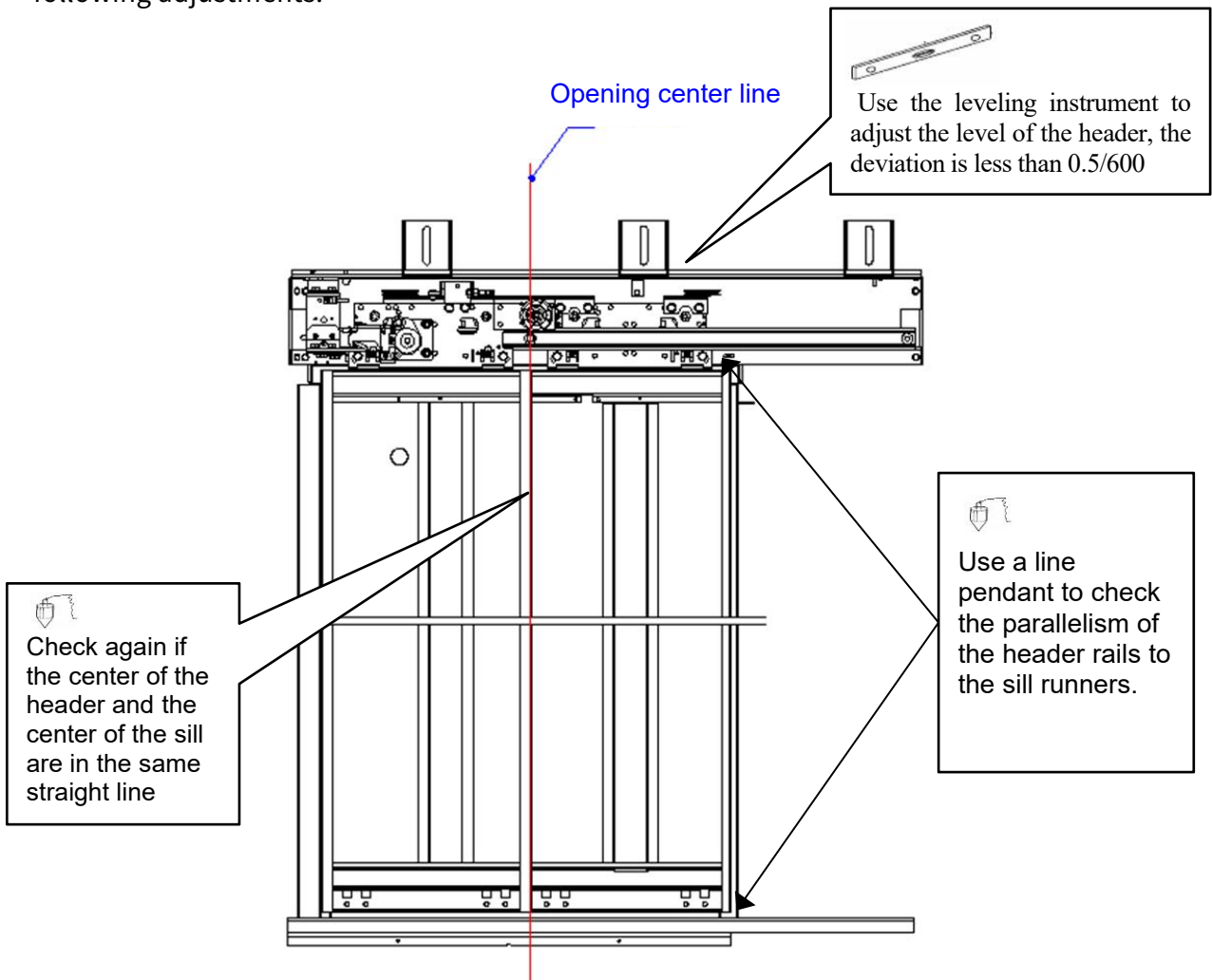

Installation of side-opening LD-2S hall door system



Pack

Check if the distance between both sides of the header and the car guide rail is consistent (as shown in the following figure):

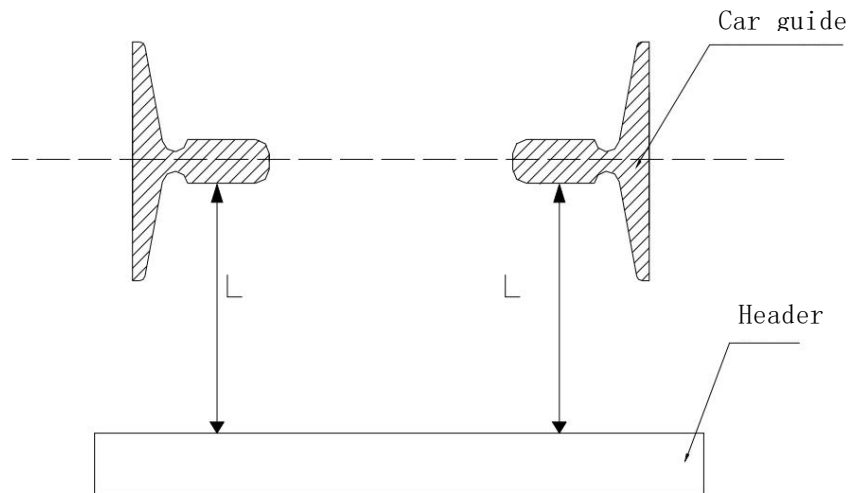

4. After the adjustment is completed, tighten the header fixing screws.

● Hall Door Panel Installation

Before installation, use a brush to clean the sundries in the door guide rail and the sill groove, and clean the protrusions, obstacles, and cement blocks on the wall that affect the opening and closing of the door.

1. Door panel installation.

(1) Install the hall door slider at the bottom of the door panel

The slider installation at the bottom of the door panel can be installed outside the landing door. After installation, put the door panel into the sill of the landing door for door panel installation. The installation depth of the slider can be adjusted up and down through the installation hole, so that the slider can effectively go deep into the sill.

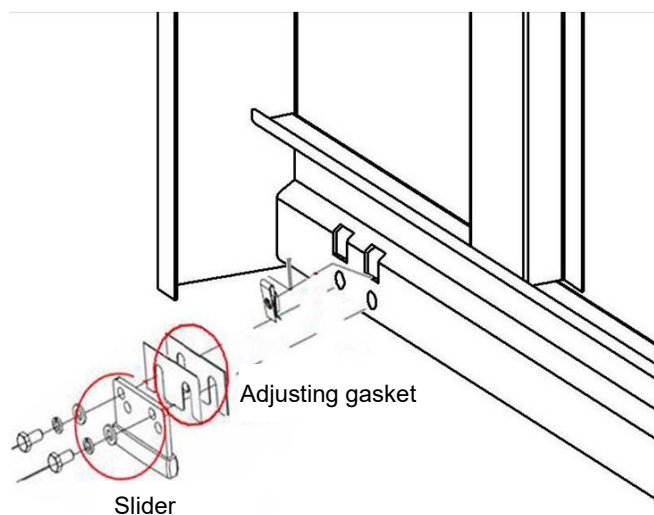

Installation of side-opening LD-2S hall door system



Pack

(2) Door hanging board is connected with hall door panel

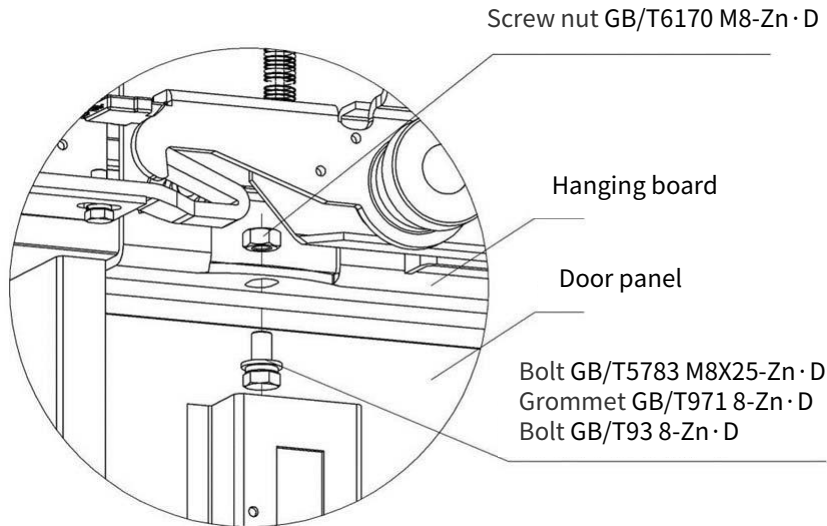

2. Adjust as follows.

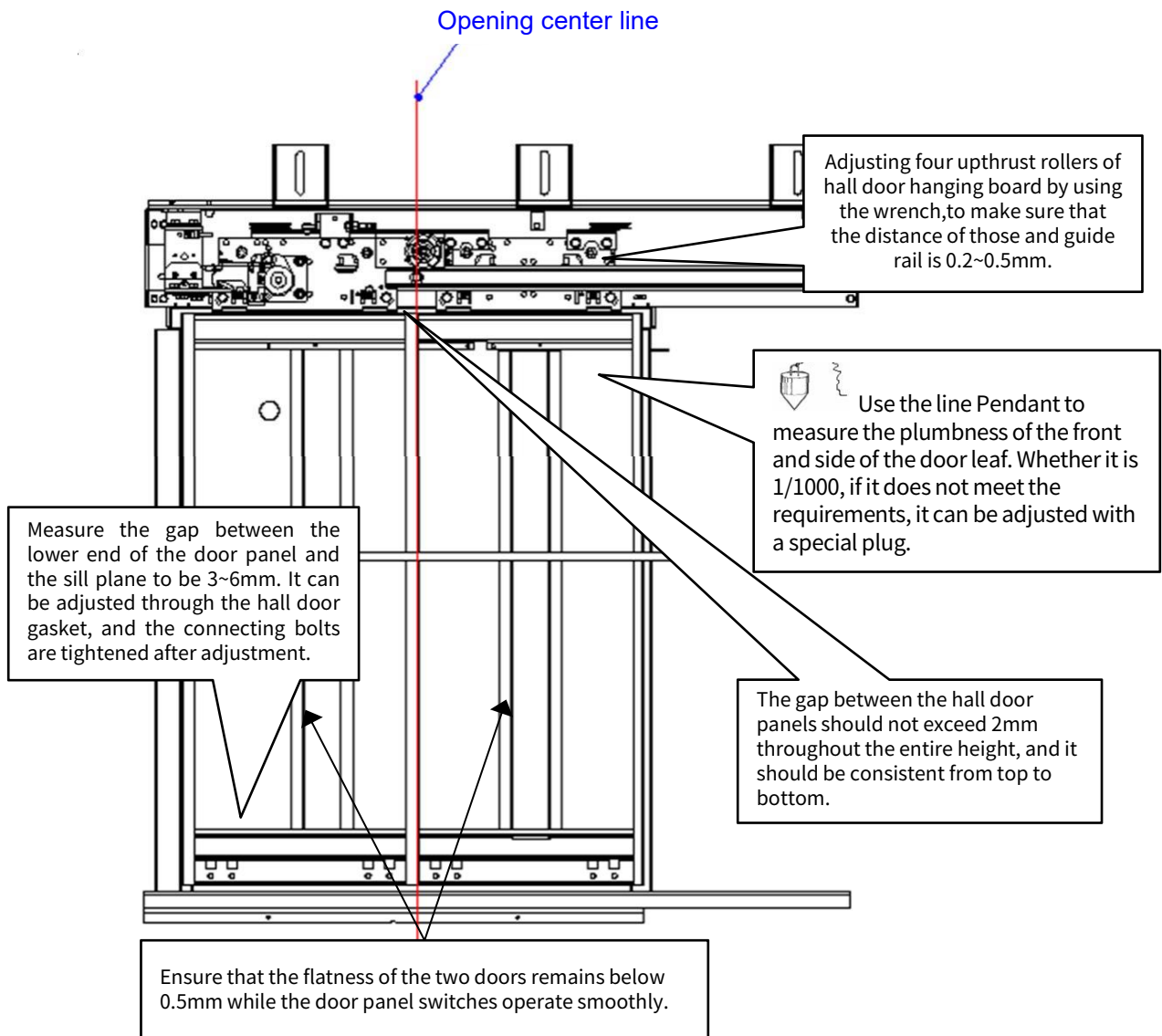

Installation of side-opening LD-2S hall door system



Pack

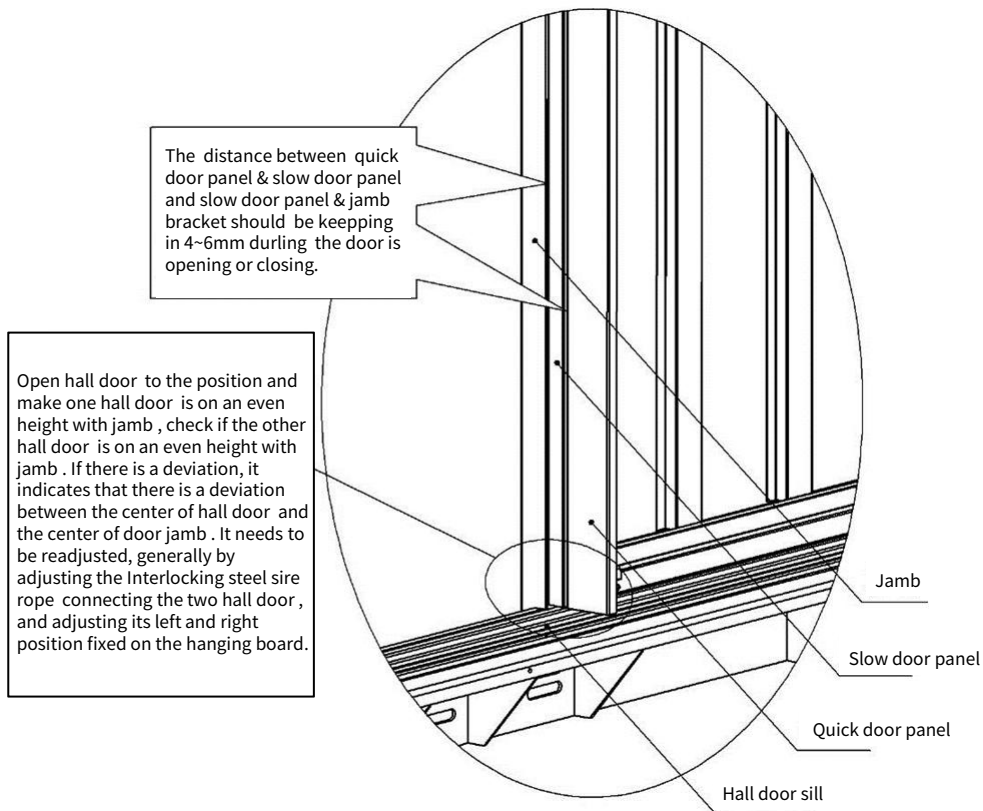

After adjustments, check that each door runs smoothly and without any obstructions.

Check whether the buffer rubber particles on the jamb of the hall door on each floor are in good condition

3. After confirming that all adjustments are completed, tighten the connecting bolts.

Installation of side-opening LD-2S hall door system



Pack

● Hall Door Lock Adjustment

The door lock of the side hall door only has the main door lock part, and the installation and adjustment of the main door lock should meet the following requirements:

1. Check and adjust the lock hook, lock arm, roller, spring, etc. before installation.
2. There is no abnormal noise when the hall door lock operates, and the lock plate and contacts of the main door lock have a movement margin.
3. After the hall door is closed, simultaneously pull the hall door with a force of 120N along the direction of the door opening at the lower part of the hall door, and the lock contacts must not detach.
4. After the hall door is closed, there should be a 2mm movable gap for the lock hook of the door lock, and the engagement degree of the lock hook (hooked size) should be at least 7mm. The contacts of the main door lock can be fine-tuned, and the adjusted contacts should ensure that At the physical center of the contact at the time of contact.

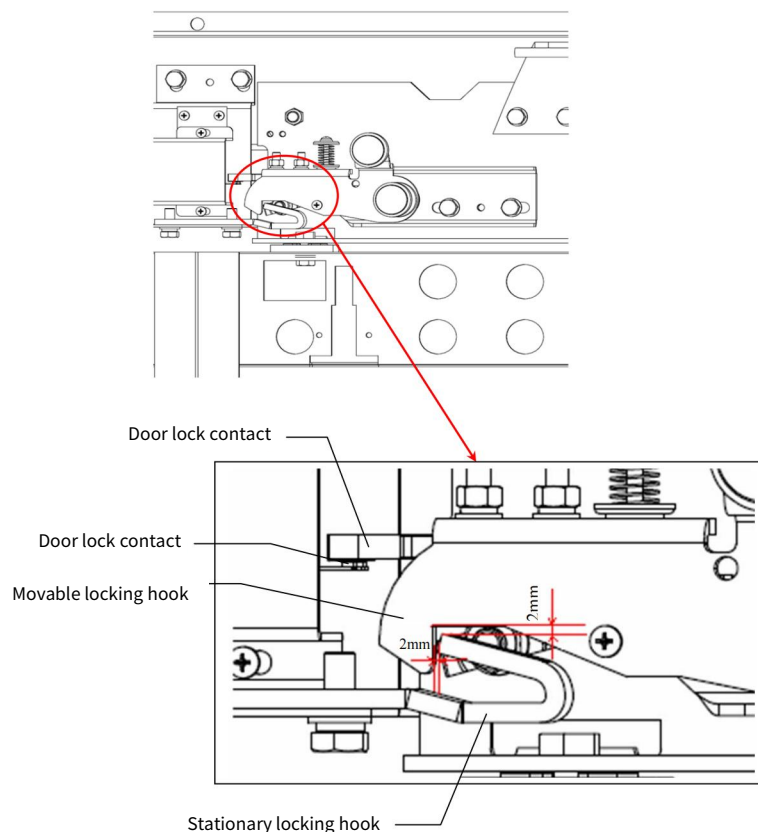

5. The static lock hook that works in conjunction with the main door lock movable lock hook can be adjusted left and right according to the movable lock hook. After adjustment, the movable lock hook is located in the center of the static lock hook.

6. After closing the hall door, pull the door with 120N force at the bottom of hall door quick door panel, and the maximum gap between quick door panel and door jamb column should be less than 20mm.

7. Hall door locks should be reliably grounded.

Installation of side-opening LD-2S hall door system



Pack

● Hall Door Forced Closing Device Installation

1. Connect and pre-tighten the hole corresponding to the side plate of the upper sill above the guide groove of the forced closing weight, and pre-tighten the connection and pre-tighten the hole corresponding to the bottom sill. Use the line pendant to adjust the plumbness of the guide groove to within 1/1000, and tighten the screws.
2. Connect the steel wire rope connecting bolt of the forced closing hammer of the hall door to the steel wire rope connecting hole on the middle door lock of the hall door header, tighten the bolt nut, place the steel wire rope into the guide groove, and then place the heavy hammer into the guide groove.

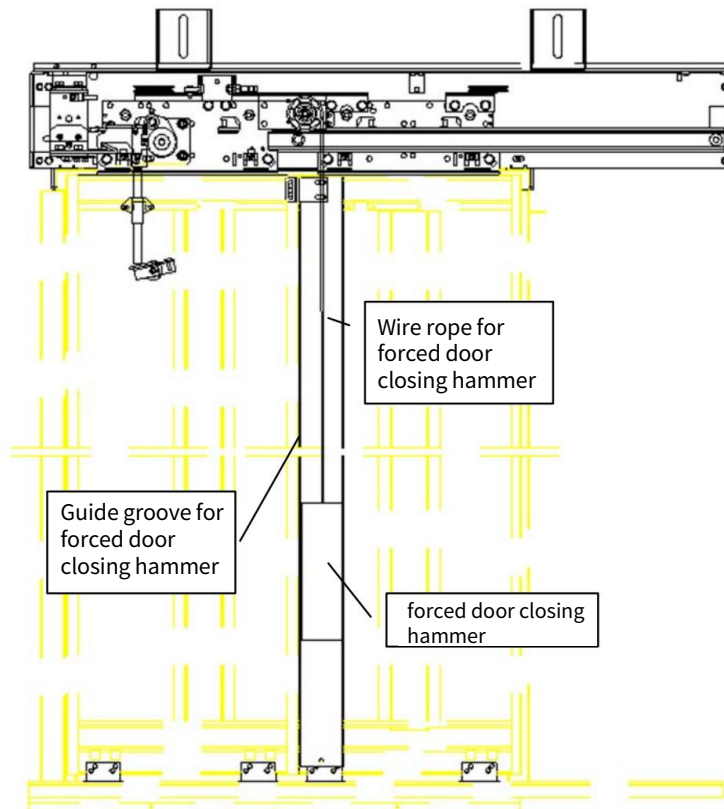

Schematic diagram of connection between hall door forced closing heavy hammer steel wire rope and middle door lock

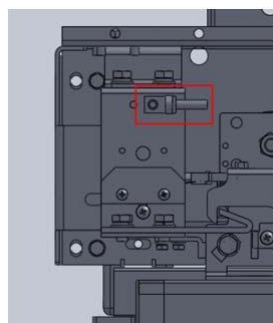

Installation of side-opening LD-2S hall door system



Pack

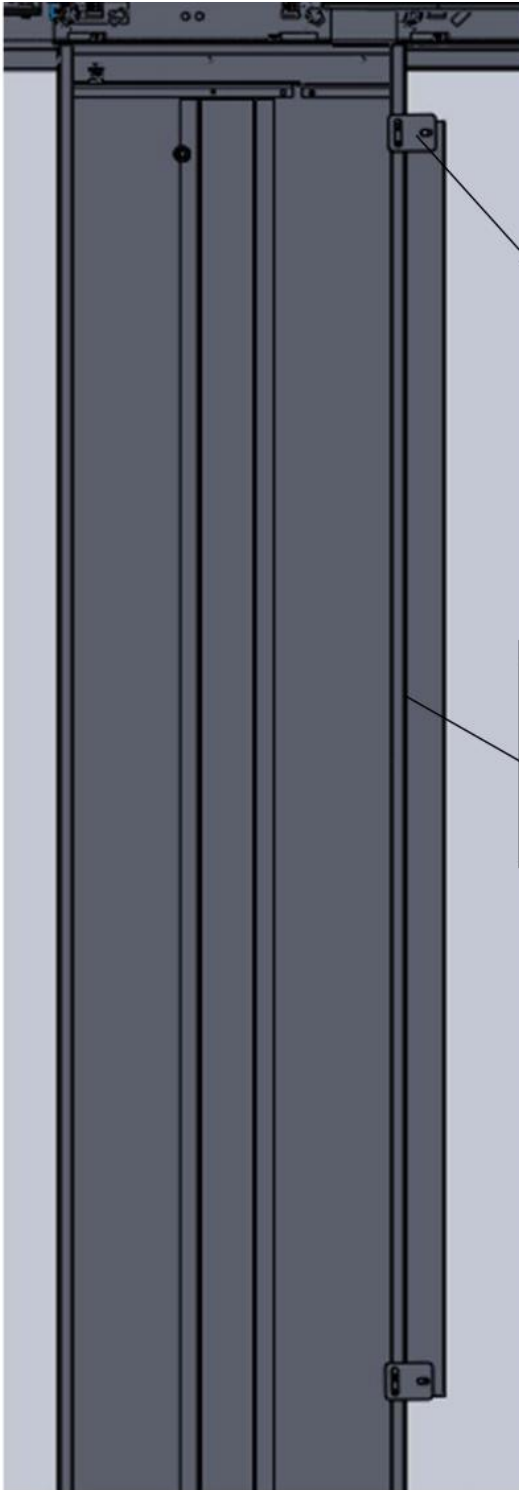

The upper and lower parts are connected with M6 bolts on the side panel of the door panel with the connecting plate

There are self-adhesive stickers on the side of the guide tube, tear off the sticker after the bolts are tightened, and bond with the door panel for reinforcement

3. Open all the hall doors to test the effect of forced door closing. The forced hammer runs without noise and moves flexibly. Forced door closing should be effective under the most adverse conditions.

Installation of side-opening LD-2S hall door system



Pack

4. Put the cover plate on the upper and lower ports of the guide tube, and then fasten it with bolts. (install only if required)

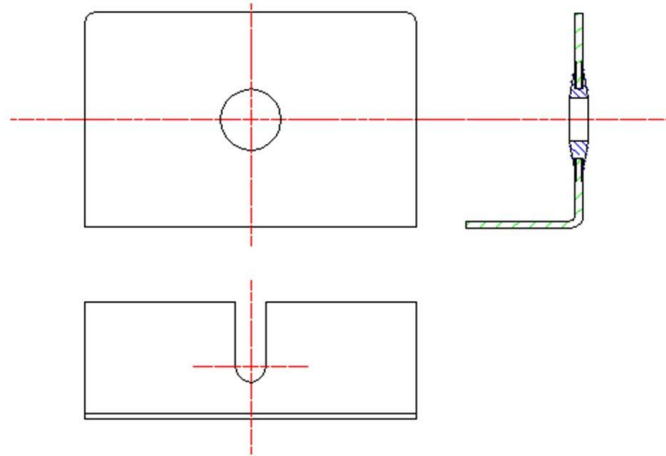

● Hall Door Sill Toe Guard Installation

5. The hall door sill toe guard requires three points to be fixed, and the screws are fastened, flat and not protruding. And the hall door sill toe guard must be fixed with flat head screws.

Diagram of hall door sill toe guard installation

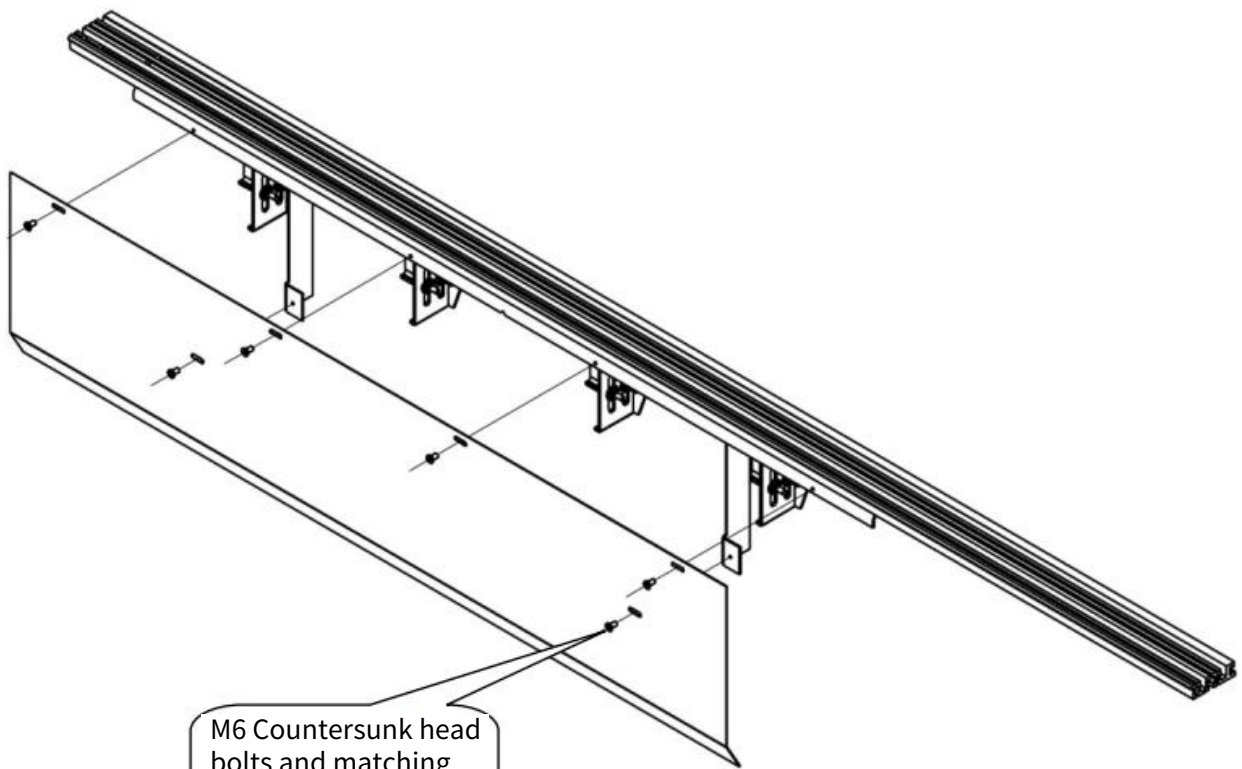

M6 Countersunk head bolts and matching nuts, spring washers, flat washers