

Installation of center-opening LD-4C hall door system



Pack

● Hall Door Sill Installation

The sill should be 2-5mm higher than the decoration ground. Before installing the sill, you must coordinate with the civil works contractor to confirm the height of the sill installation. The civil work contractor is required to provide the baseline of the floor for accurate construction.

1. Assemble the sill installation bracket (as shown in the following figure)

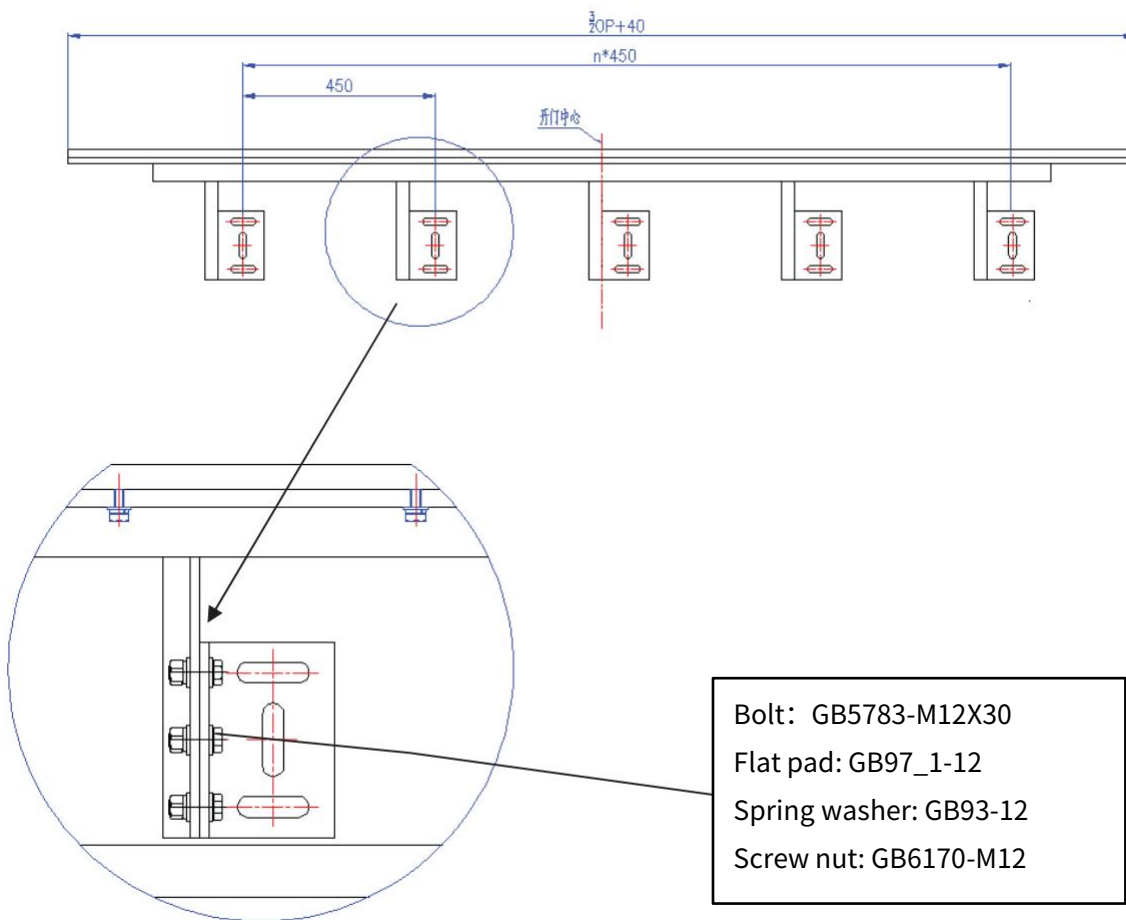

Attention: due to the need for appropriate adjustment of the sill components during final installation based on on-site conditions, pre tightening of the fasteners is sufficient in this step.

Installation of center-opening LD-4C  
hall door system

Pack

2. Fixed combination bracket inside the shaft.

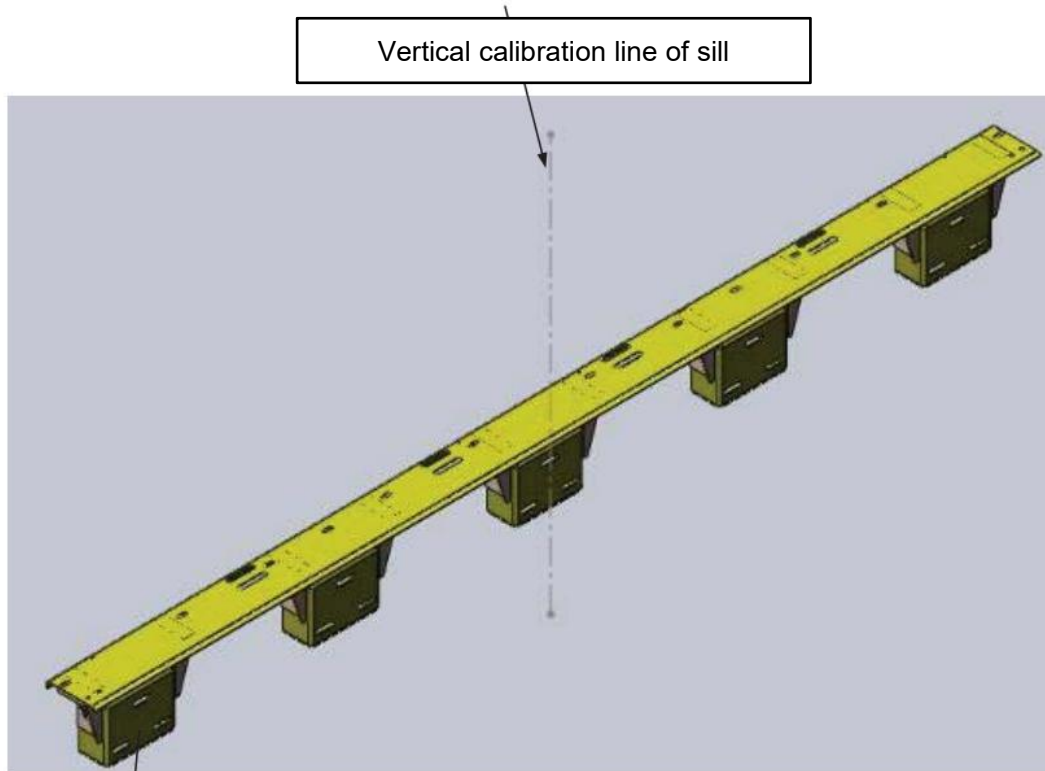

sill bracket

(1) Determine the installation position of the sill bracket.

(2) After the installation position of the sill is basically determined based on the centerline, use a marking pen to make a mark on the wall through the installation hole of the bracket, and then use an impact drill to drill holes on the mark. Use expansion bolts to fix the sill bracket on the wall (as shown in the following figure), and lock the bracket tightly.



# Installation Manual

Installation of center-opening LD-4C  
hall door system



Pack

3. Install the foot board onto the pallet assembly.

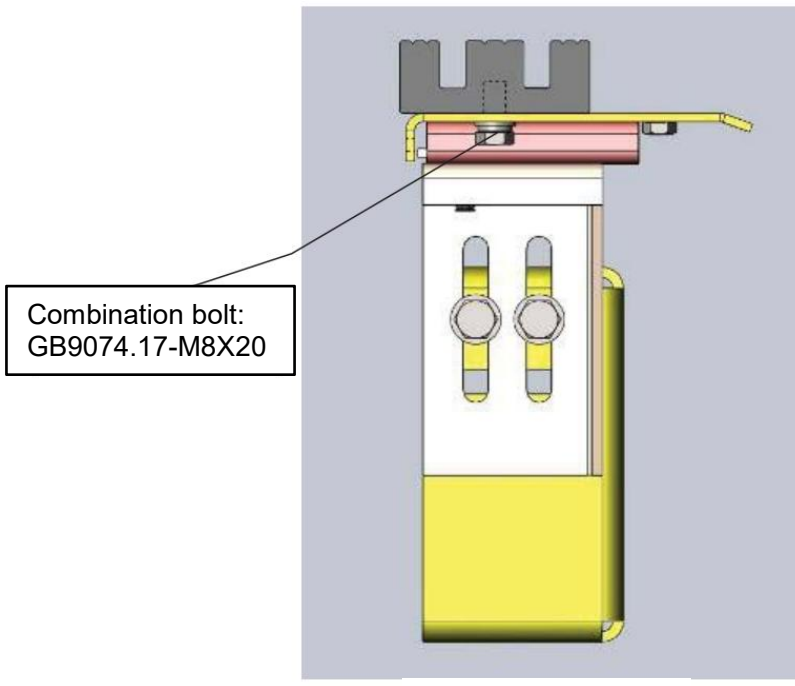

Side view

4. Make the adjustments shown in the following figure, and after the adjustment and installation are confirmed to be correct, lock all bolts tightly.

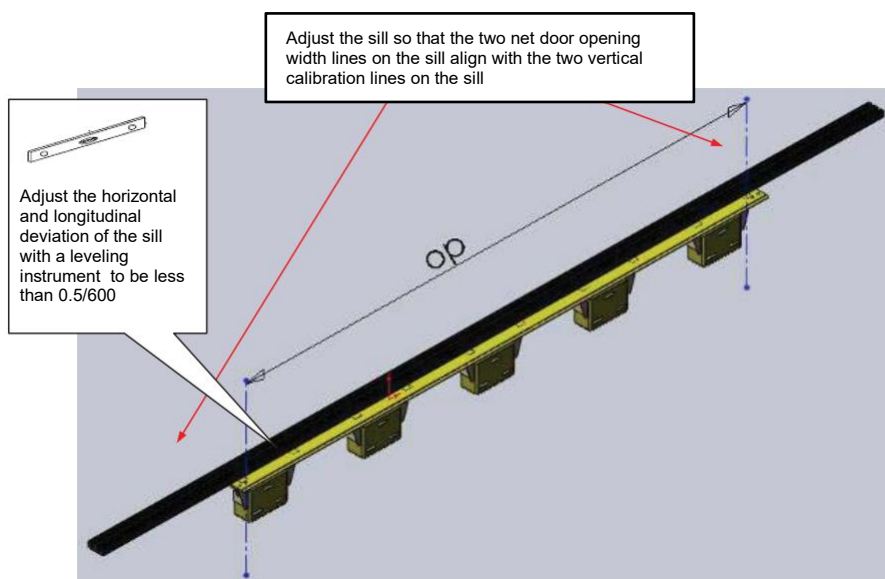

Installation of center-opening LD-4C hall door system



Pack

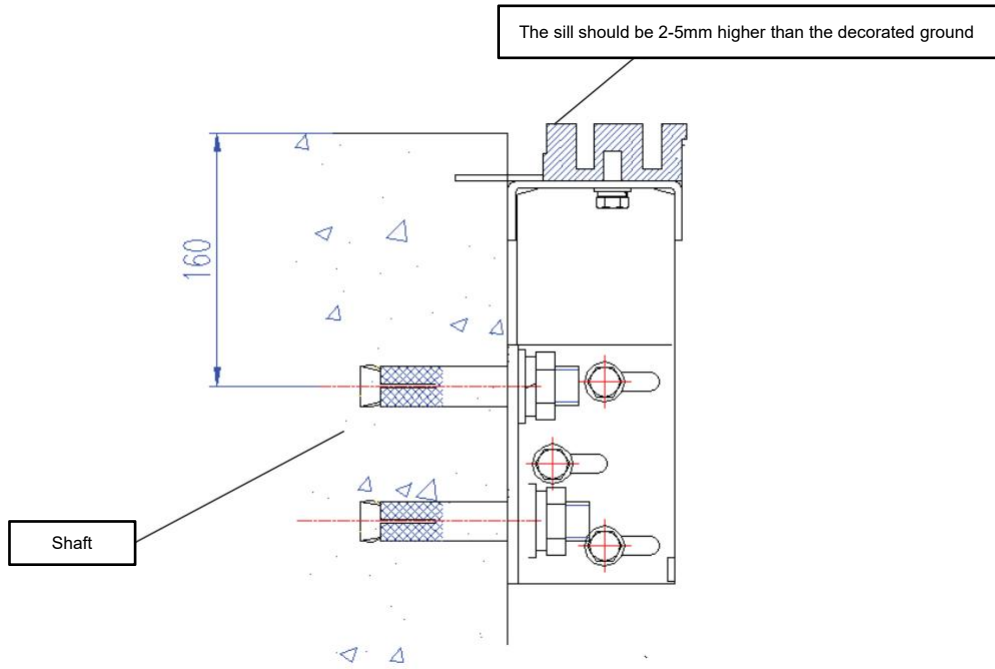

● Hall Door Jamb Installation

1. Jamb assembly.

(1) Determine the installation position of the sill bracket. Divide the top frame of the door jamb and extend it to both sides with the center line as the benchmark, and mark the position when the door is fully opened with a marker (that is the clear opening width line).

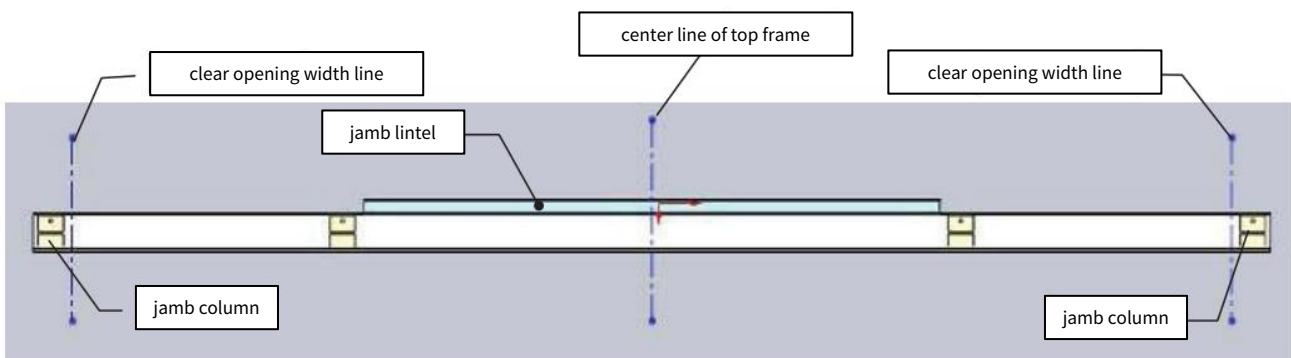

# Installation Manual

Installation of center-opening LD-4C hall door system



Pack

(2) Assemble the two outer jamb columns and the door top frame according to these two net door opening lines, and install the header installation bracket on the door top frame.

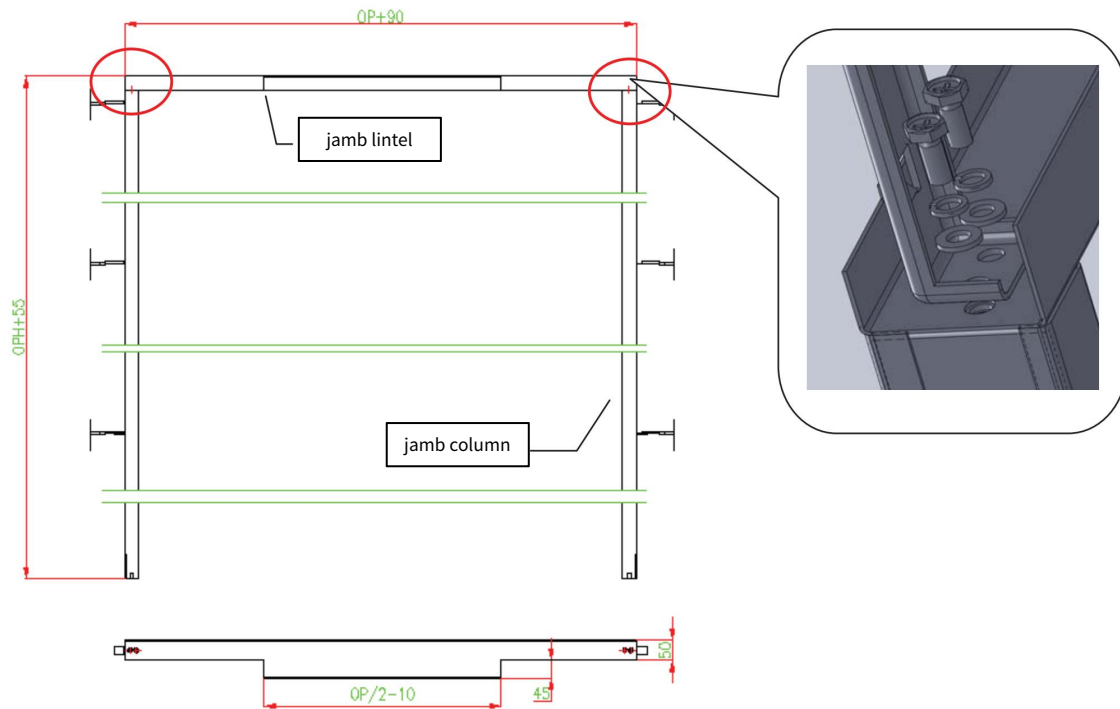
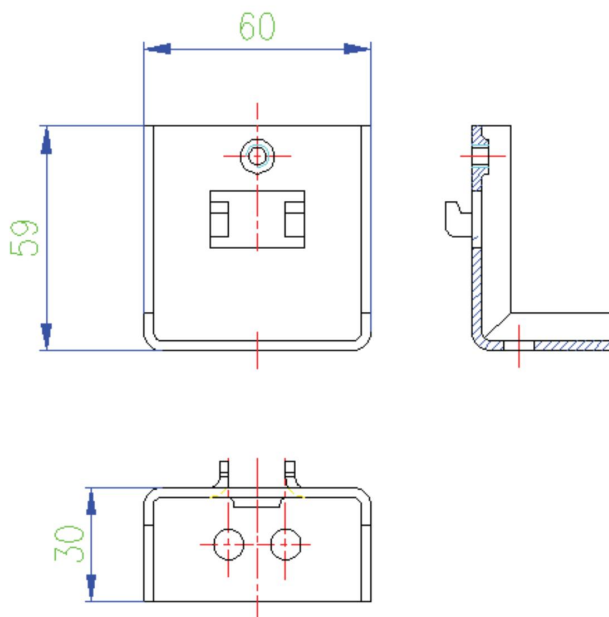

Figure of installing the header suspension bracket on Jamb:



# Installation Manual

## Installation of center-opening LD-4C hall door system



Pack

2. After combining the outer jamb, connect the lower fixing foot of the jamb with the installation hole of the sill installation jamb using bolts.

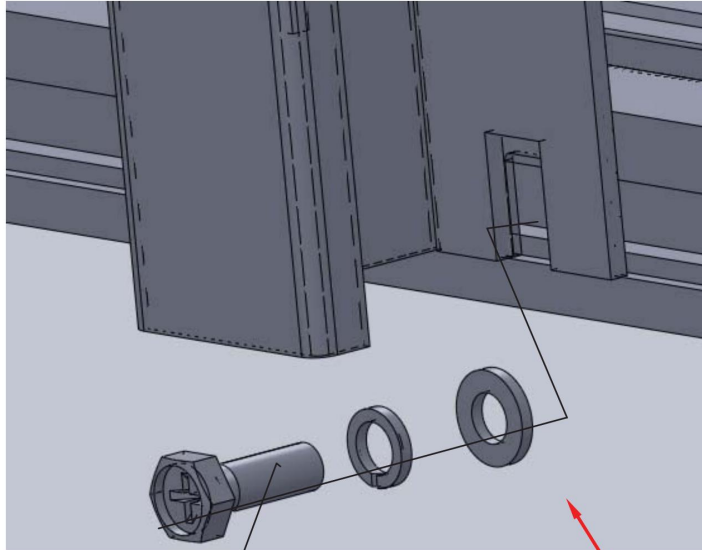

Bolt: GB5783-M8X12  
Flat pad: GB97\_1-8  
Spring washer: GB93-8

After the lower end of the jamb is fixed to the sill, use a square to measure whether the inner width of the door is aligned with the plumb calibration line of the sill. If not, make appropriate adjustments and then tighten the bolts

### 3. Connection and fixation between jamb and shaft wall

(1) Determine the fixed connection point position between the shaft and Jamb

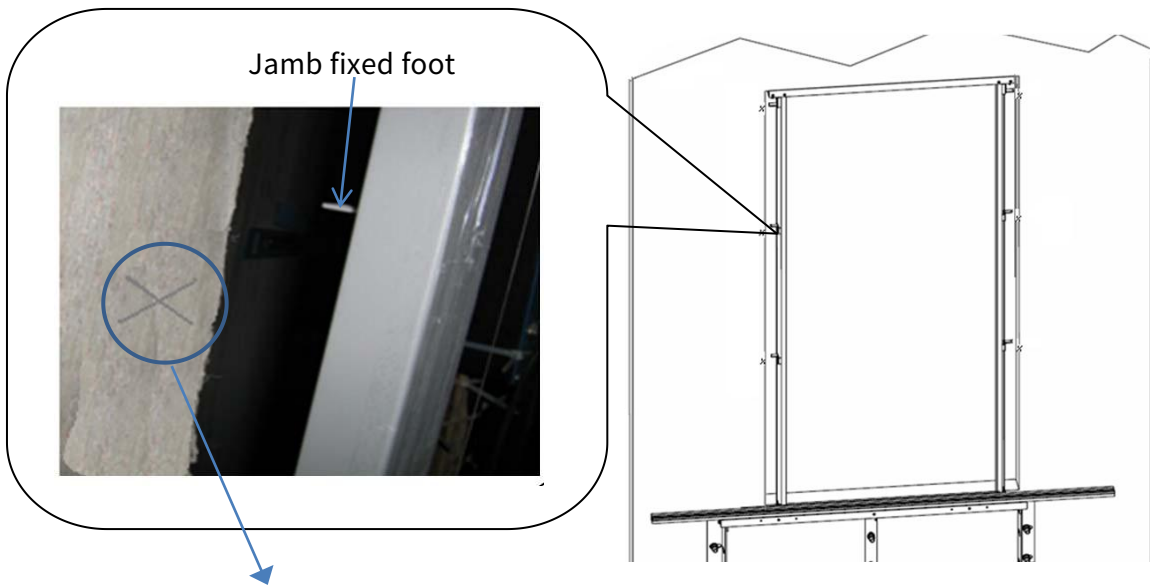

Mark with a marker pen on the door opening wall at the horizontal distance from the fixed foot of the jamb column.

# Installation Manual

Installation of center-opening LD-4C hall door system



Pack

(2) Use an impact drill to drill holes at the mark on the shaft wall, fix the expansion bolt on the shaft wall, and tighten the nut of the expansion bolt.

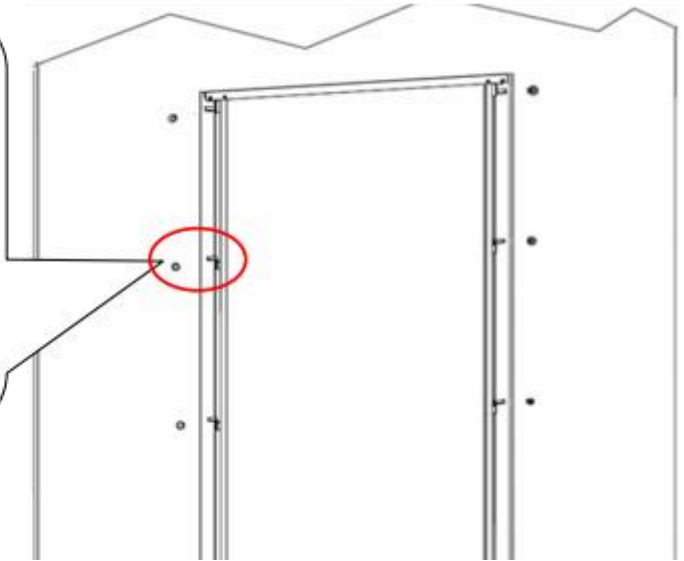

(3) After determining the left, right, front and rear positions of the jamb, fix the jamb to prevent it from moving.

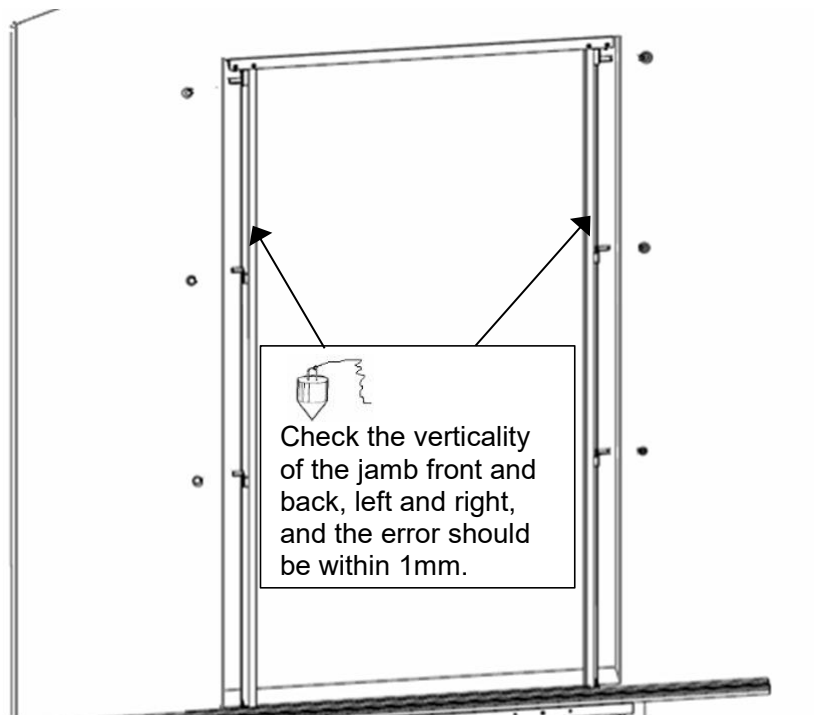

Installation of center-opening LD-4C  
hall door system



Pack

(4) Use  $\Phi 8\text{mm} \times A 150\text{mm}$  round steel is used to fix the top two fixed feet of the Jamb column by welding them with expansion bolts (as shown in the following figure).

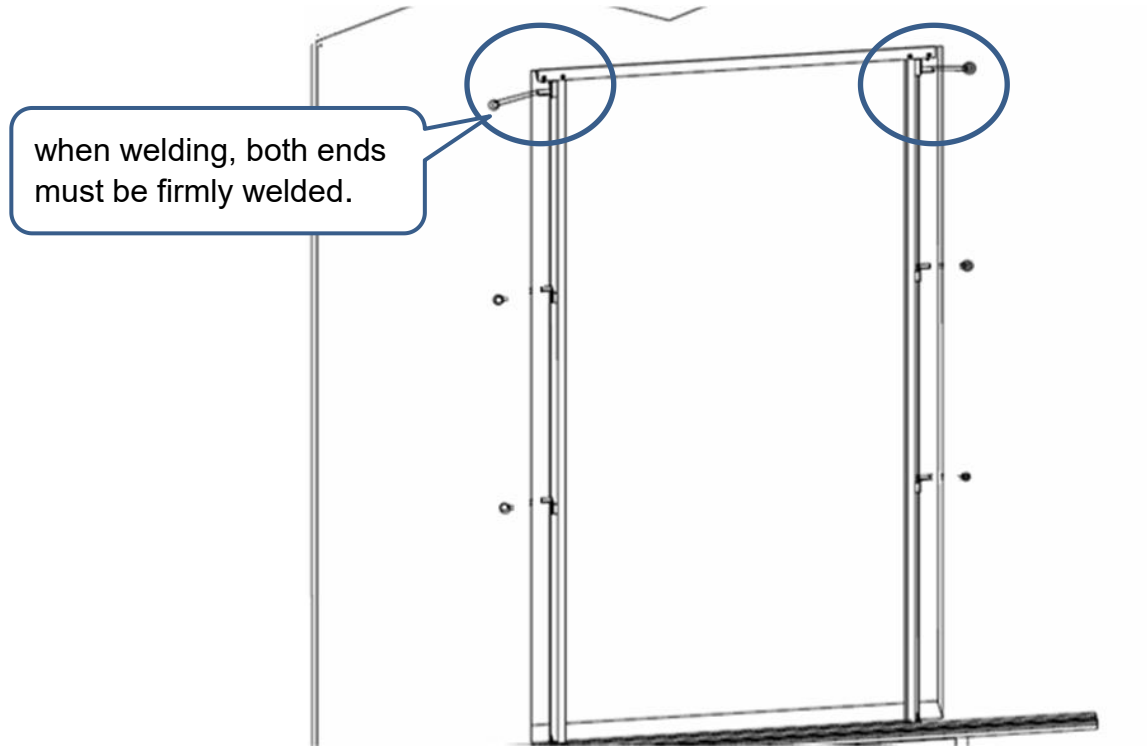

If the verticality and torsion meet the requirements, weld the fixed feet of the jamb column one by one with the expansion bolts (as shown in the following figure):

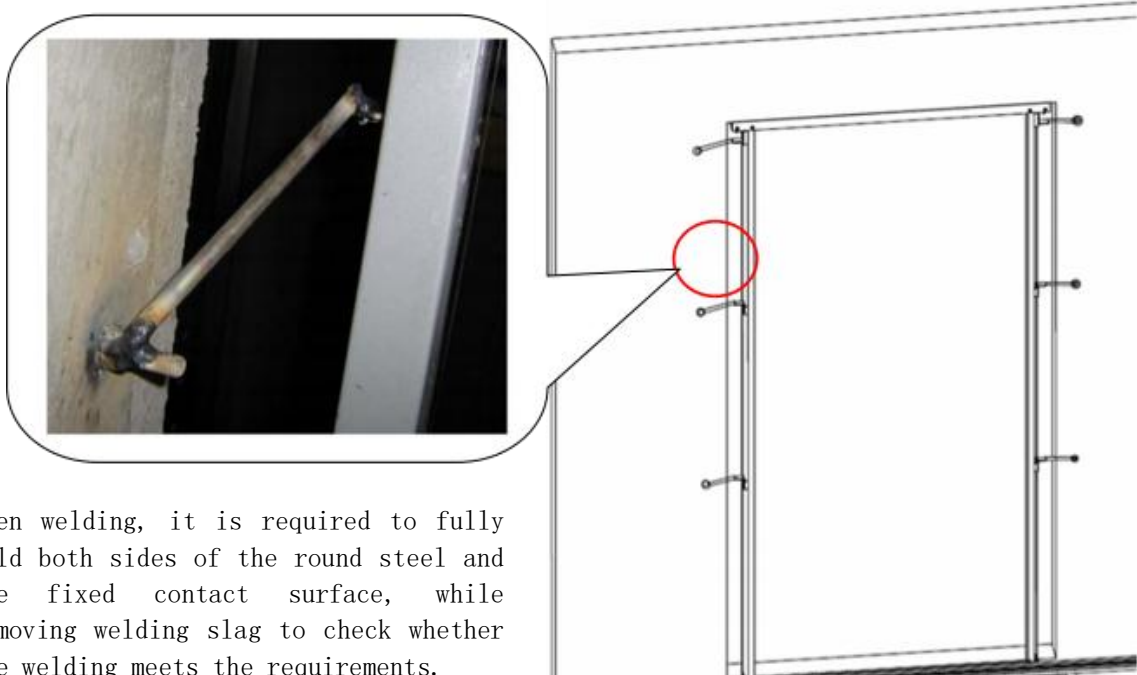

When welding, it is required to fully weld both sides of the round steel and the fixed contact surface, while removing welding slag to check whether the welding meets the requirements.



Installation of center-opening LD-4C hall door system



Pack

● Hall Door Header Installation

1. First, place the hall door header on the header bracket of the door cover (connected with bolts), keep the center point of the header aligned with the center point of the hall door sill, and place it according to the fixing frame of the hall door header (2 pieces in total) The position of the bolt fixing hole is marked on the shaft wall with a marker pen to mark the position of the fixing bolt.

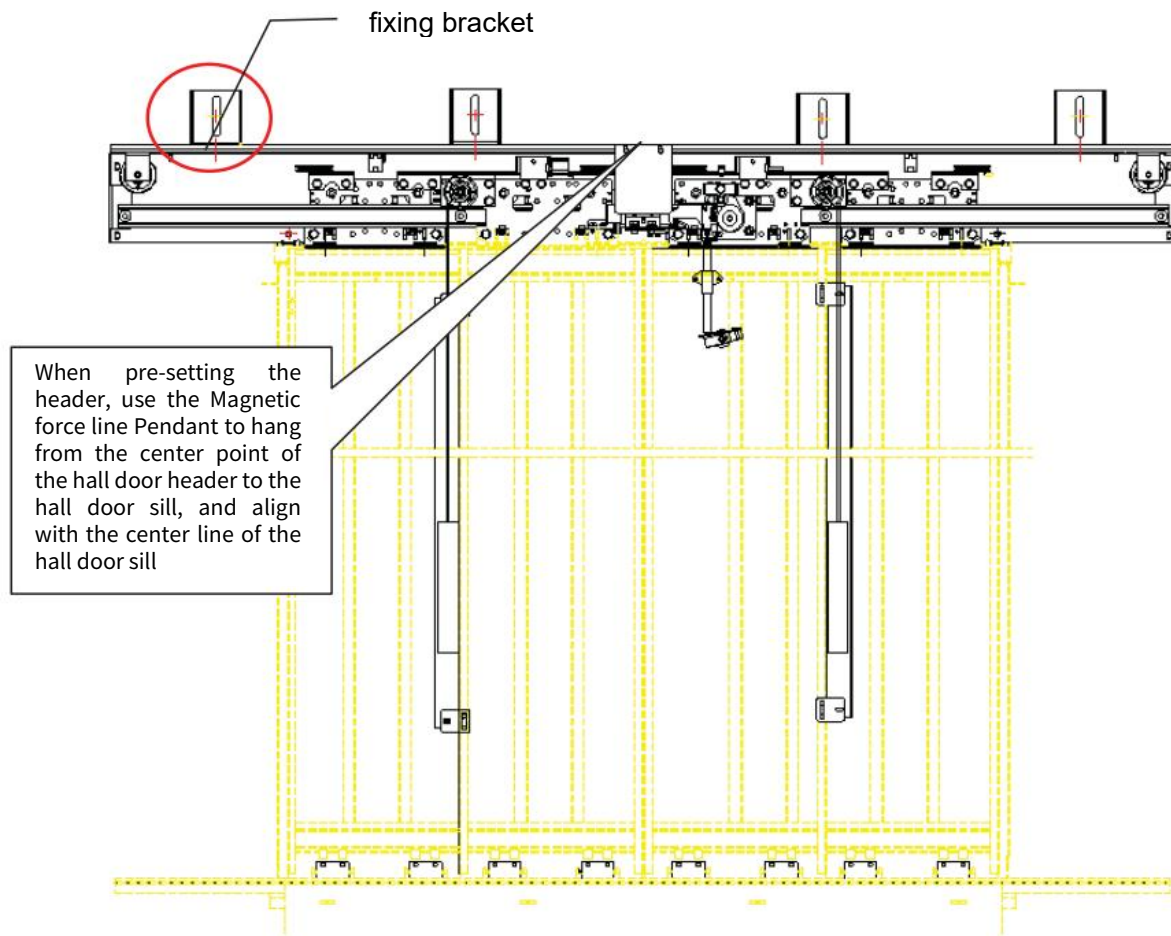

2. Drill holes at the marked positions with a rotary hammer and fix the expansion bolts.

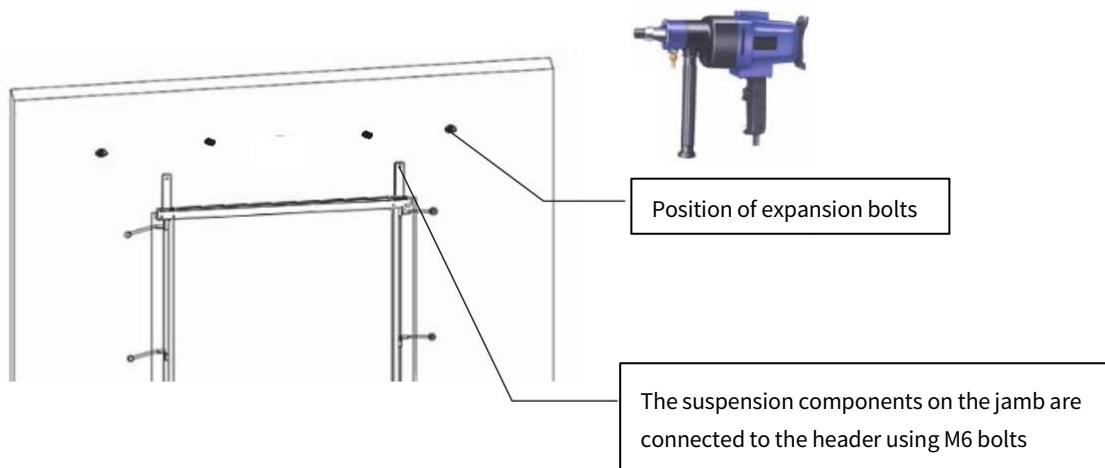

Installation of center-opening LD-4C hall door system



Pack

3. Connect the hall door header bracket, pass the expansion bolts on the shaft wall through the fixing holes of the hall door header bracket, and pre tighten the screws. Then make the following adjustments.

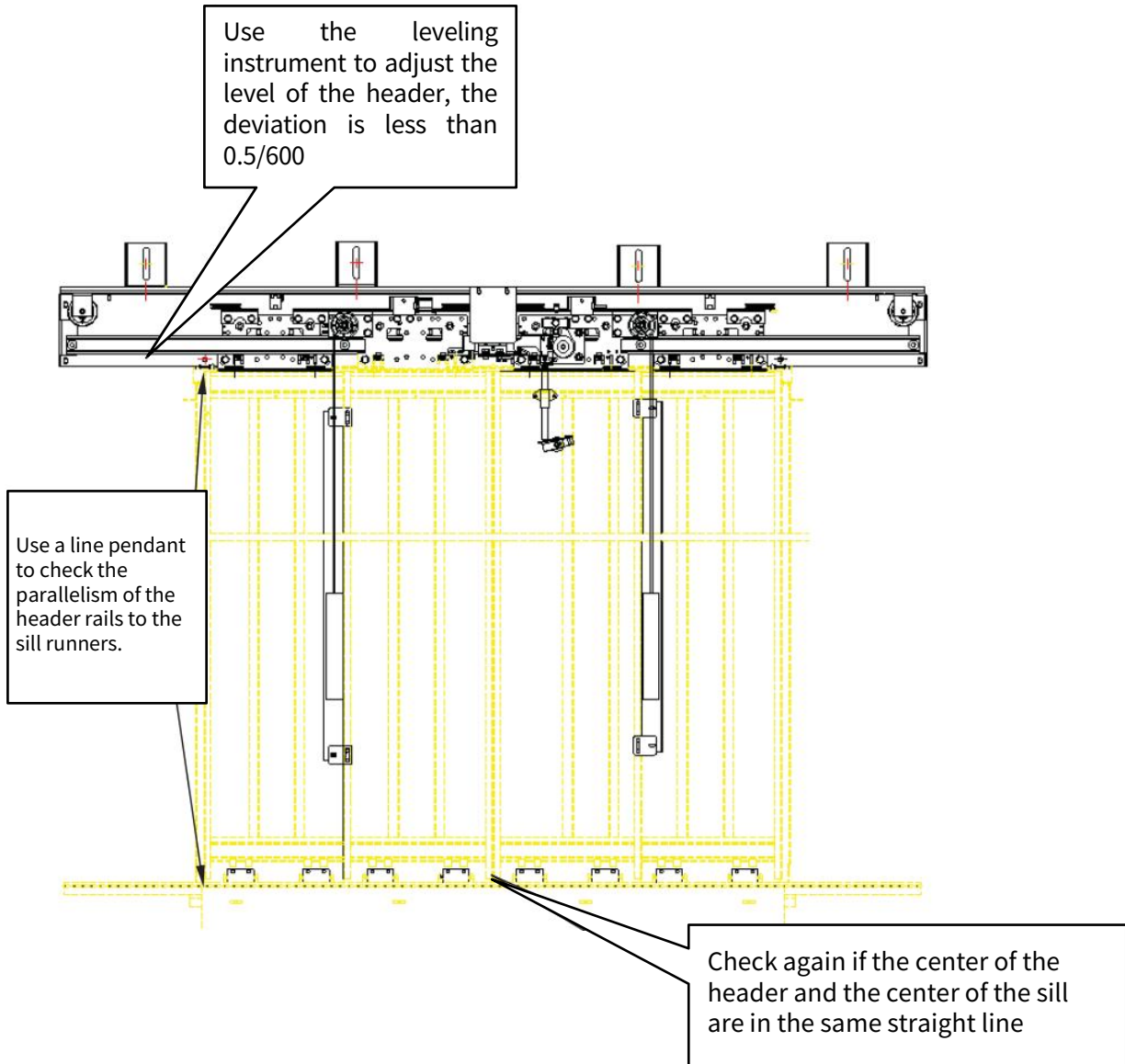

Check if the distance between both sides of the header and the car guide rail is consistent (as shown in the following figure):

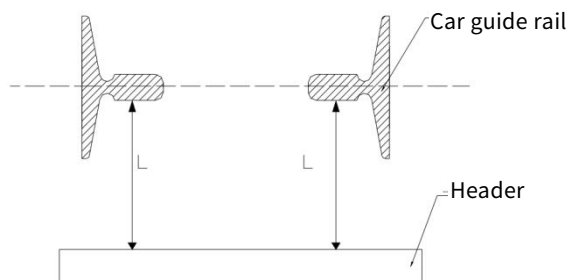

4. After the adjustment is completed, tighten the header fixing screws.

Installation of center-opening LD-4C  
hall door system

Pack

## ● Hall Door Panel Installation

Before installation, use a brush to clean the sundries in the door guide rail and the sill groove, and clean the protrusions, obstacles, and cement blocks on the wall that affect the opening and closing of the door.

## 1. Door panel installation.

(1) Install the hall door slider at the bottom of the door panel

The slider installation at the bottom of the door panel can be installed outside the landing door. After installation, put the door panel into the sill of the landing door for door panel installation. The installation depth of the slider can be adjusted up and down through the installation hole, so that the slider can effectively go deep into the sill.

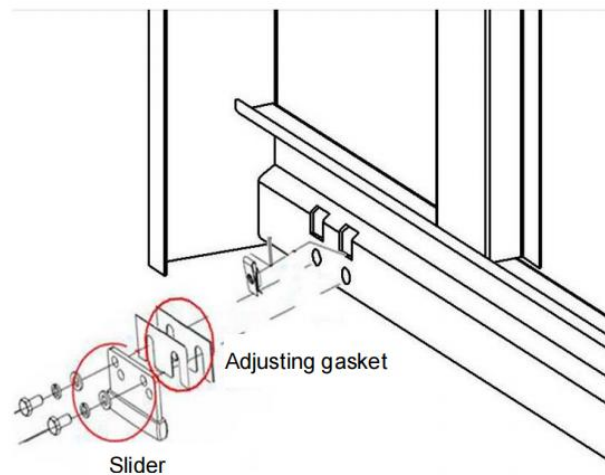

(2) Door hanging board is connected with hall door panel by using M8 combination bolt and screw nut.

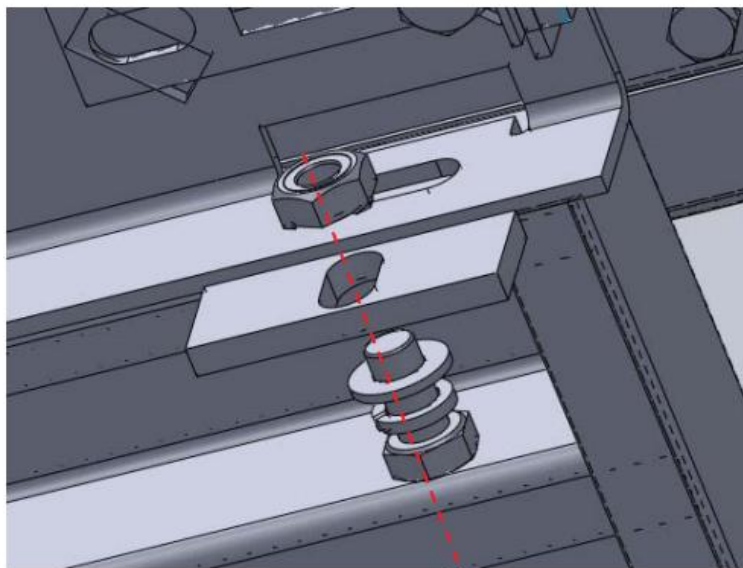

Installation of center-opening LD-4C hall door system



Pack

2. Adjust as follows.

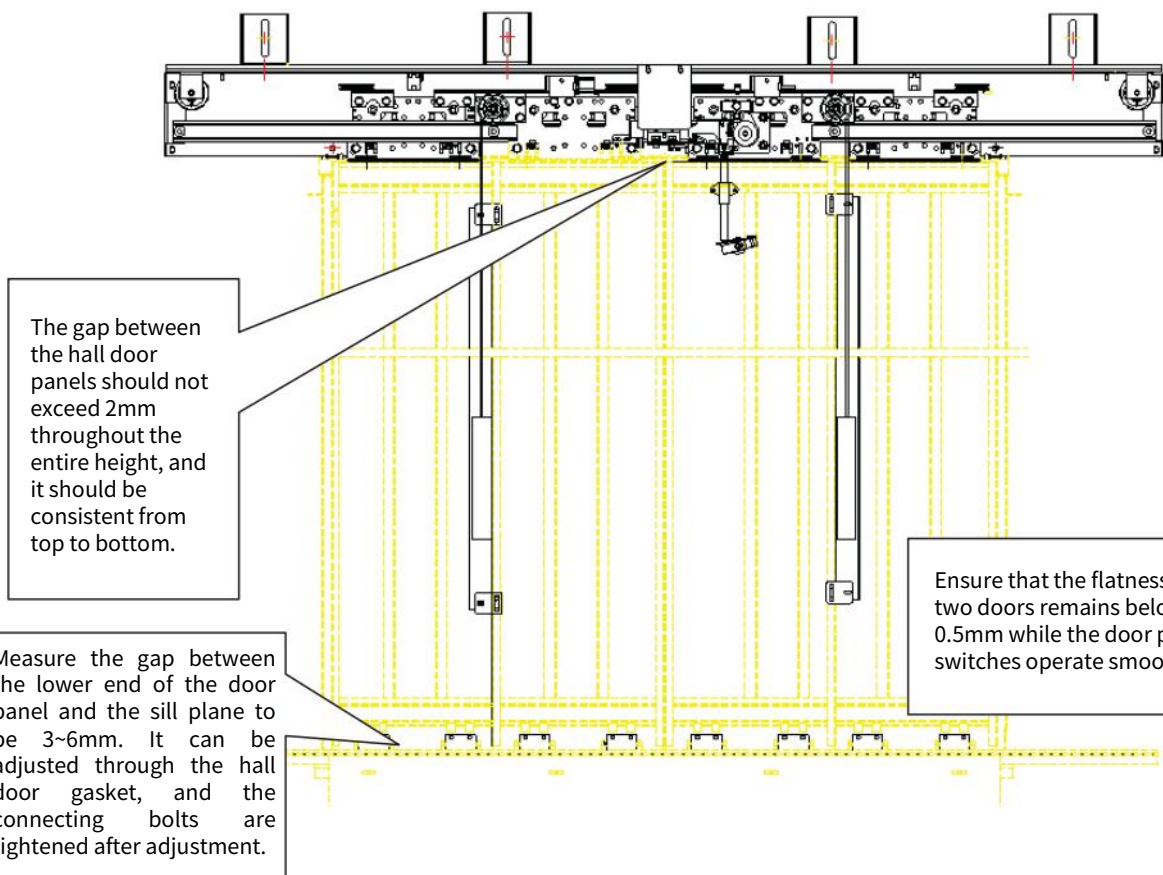
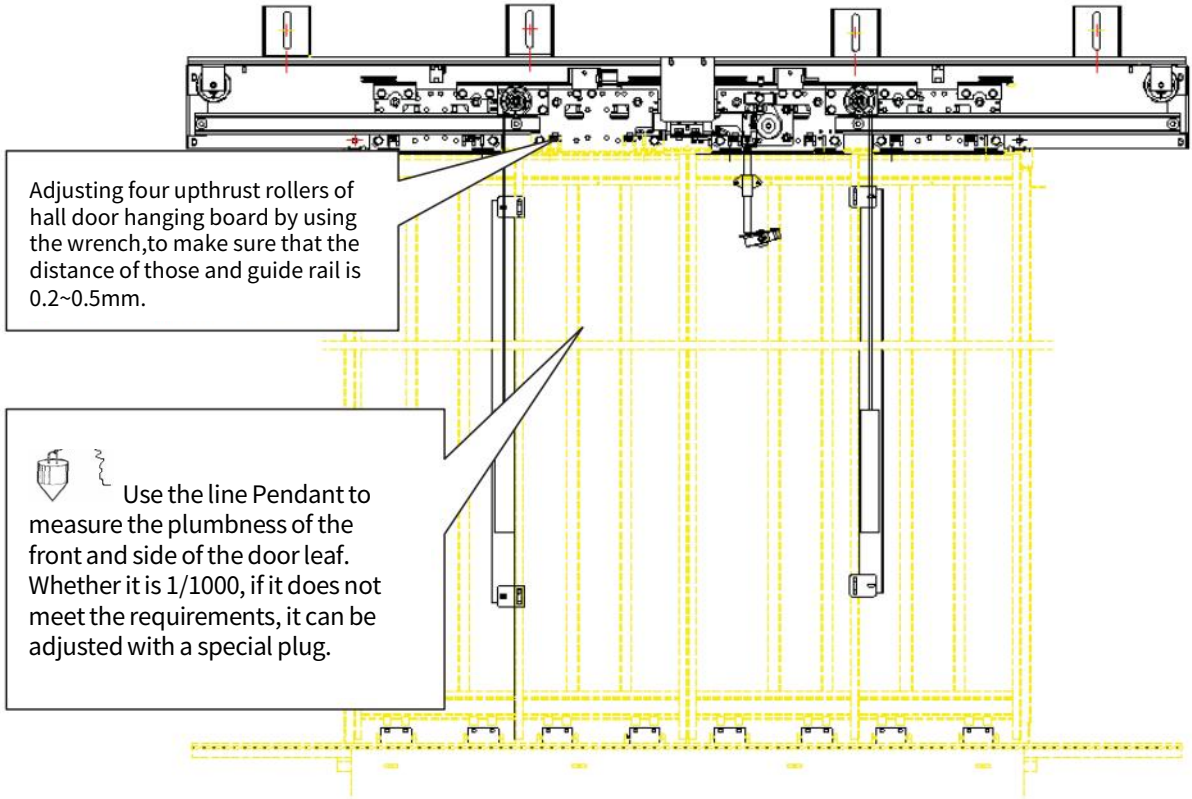



Installation of center-opening LD-4C  
hall door system

Pack

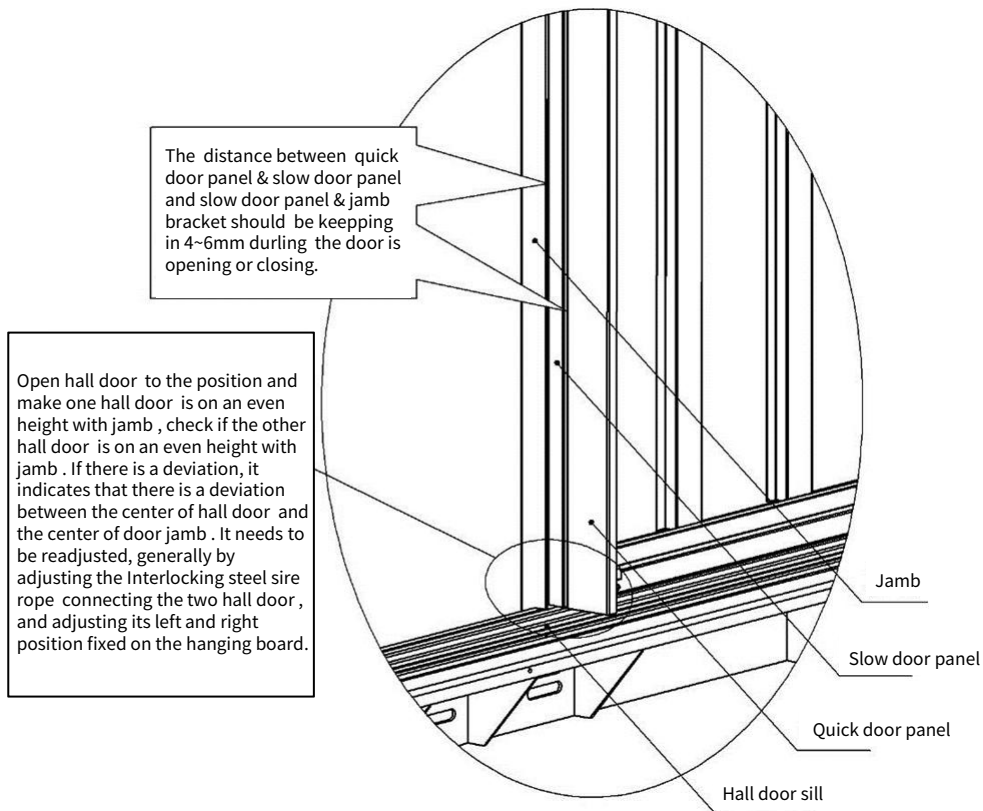

After adjustments, check that each door runs smoothly and without any obstructions.

Check whether the buffer rubber particles on the jamb of the hall door on each floor are in good condition

3. After confirming that all adjustments are completed, tighten the connecting bolts.

Installation of center-opening LD-4C  
hall door system



Pack

### ● Hall Door Lock Adjustment

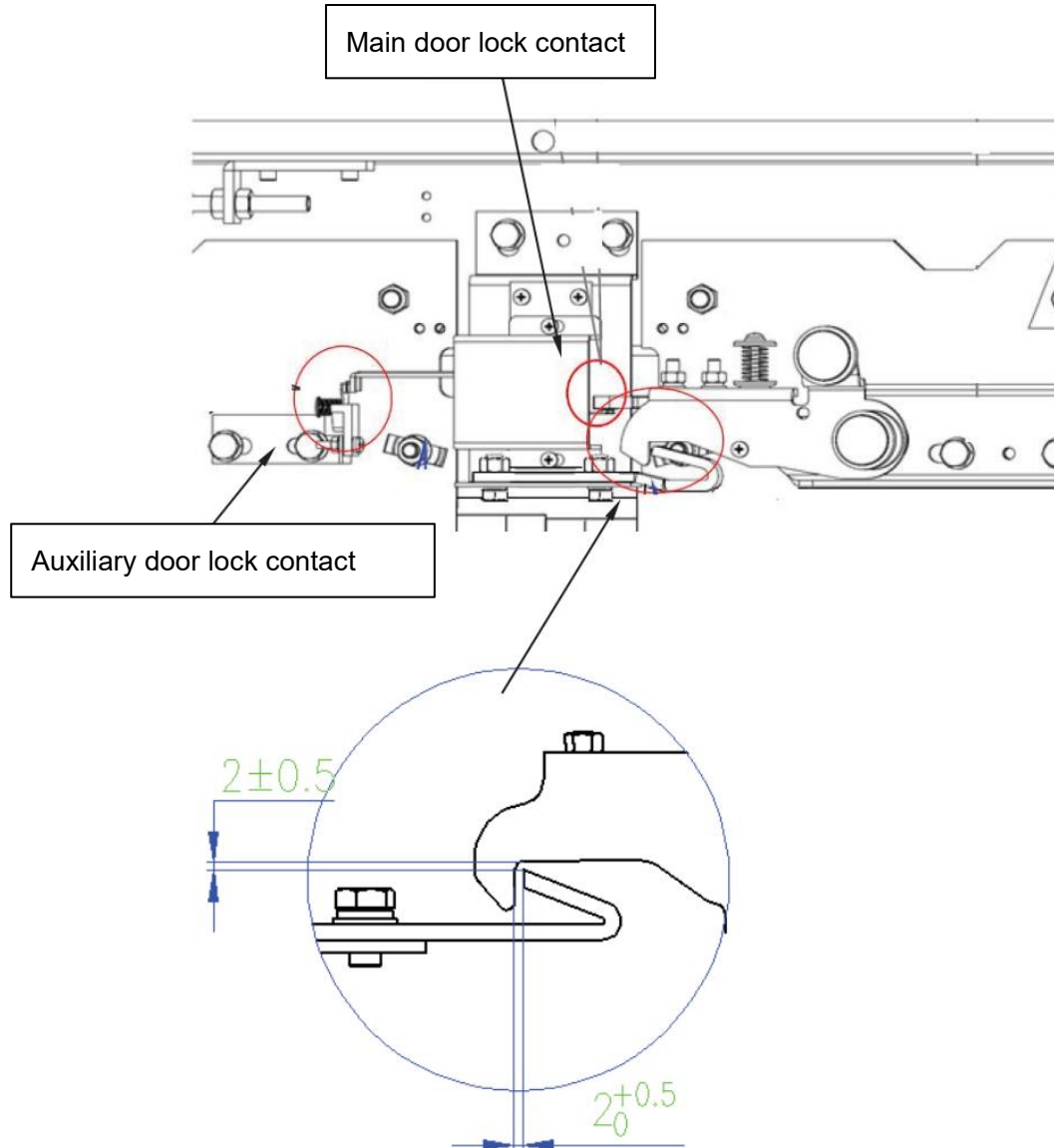

Note:

1. The engagement of the locking hook should be between 7-9mm;
2. Align the center of the engagement between the locking hook and the locking tongue in the front and rear directions;
3. The moving contact of the door lock engages with the stationary contact in the center and can be adjusted with a stopper. After the door is closed in place, the compression amount of the contact pad is 2-4mm;
4. For a split door, pull both hall doors simultaneously with a force of 300N along the direction of the door opening. At any point, the distance between the door panels should be  $\leq 50$ mm. And both the main and secondary door locks cannot be disconnected;
5. The gap between the hall door lock roller and the car door sill is 5-10mm;
6. The hall door lock is reliably grounded.

Installation of center-opening LD-4C  
hall door system

Pack

**● Hall Door Forced Closing Device Installation**

1. Connect and pre-tighten the hole corresponding to the side plate of the upper sill above the guide groove of the forced closing weight, and pre-tighten the connection and pre-tighten the hole corresponding to the bottom sill. Use the line pendant to adjust the plumbness of the guide groove to within 1/1000, and tighten the screws.
2. Connect the steel wire rope connecting bolt of the forced closing hammer of the hall door to the steel wire rope connecting hole on the middle door lock of the hall door header, tighten the bolt nut, place the steel wire rope into the guide groove, and then place the heavy hammer into the guide groove.

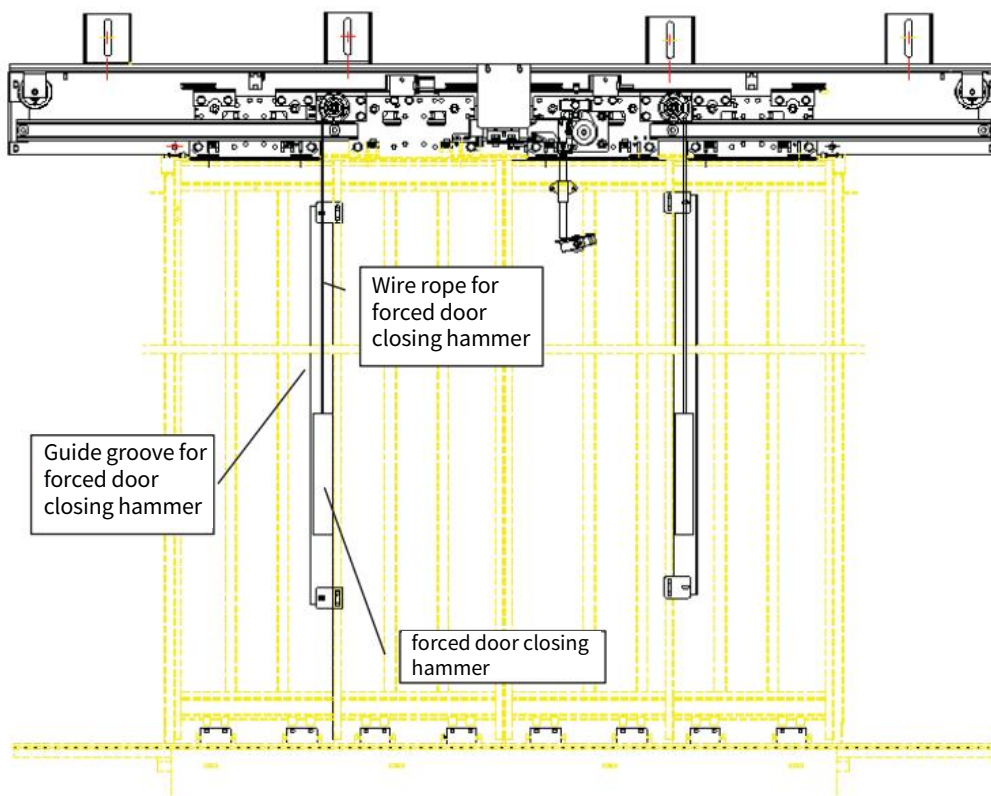

Schematic diagram of connection between hall door forced closing heavy hammer steel wire rope and middle door lock

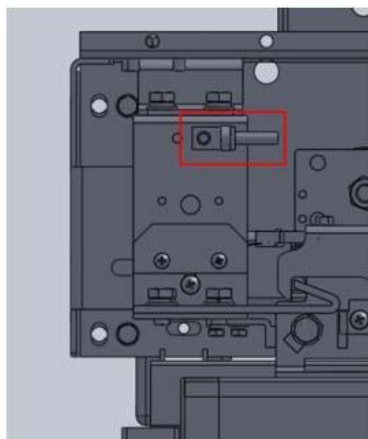

Installation of center-opening LD-4C  
hall door system

Pack

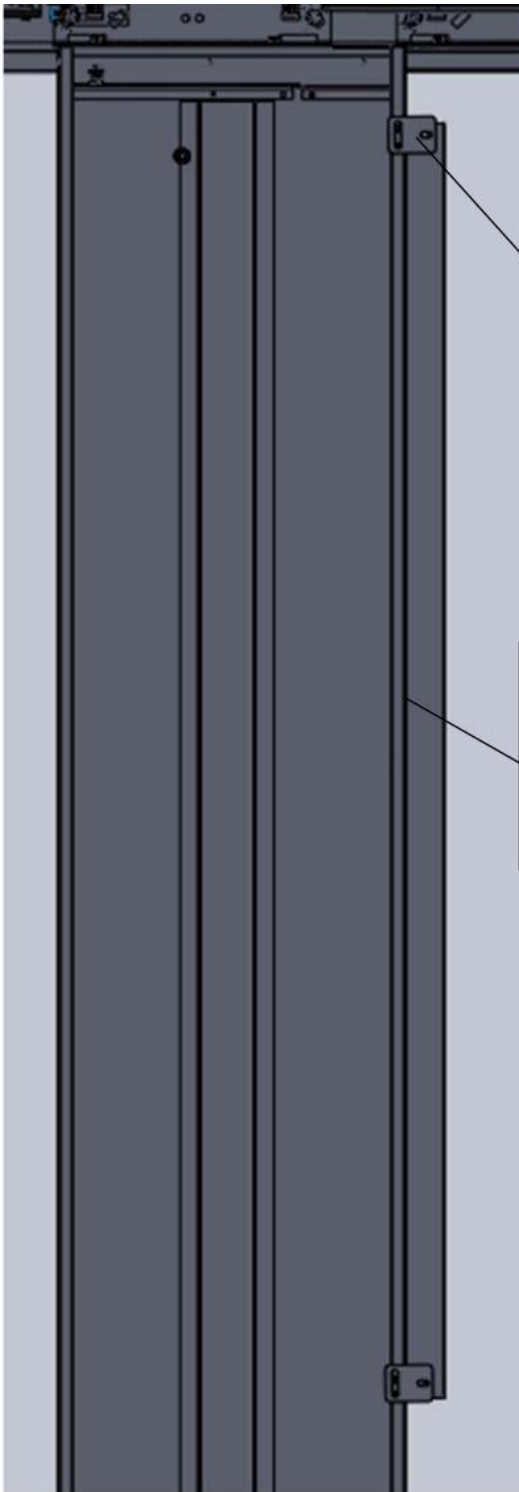

The upper and lower parts are connected with M6 bolts on the side panel of the door panel with the connecting plate

There are self-adhesive stickers on the side of the guide tube, tear off the sticker after the bolts are tightened, and bond with the door panel for reinforcement

3. Open all the hall doors to test the effect of forced door closing. The forced hammer runs without noise and moves flexibly. Forced door closing should be effective under the most adverse conditions.



Installation of center-opening LD-4C  
hall door system



Pack

● **Hall Door Sill Toe Guard Installation**

Diagram of hall door sill toe guard installation:

